



**15. Disposal:**



Please disposal of the unserviceable device according to the current statutory requirements.

**16. Technical specification:**

All:

Voltage 90-240Vac, 50/60Hz

LED Life: 50,000 Hours

Fuse: F1A

Model	Power Consumption	Beam Angle	LED Type	LED Data	Dimensions	Weight
SP-36	10W	25°	10mm Ø	36 (R:12, G:12, B:12)	180 x 120 x 150mm	0.84kg
SP-56	25W	25°	10mm Ø	108 (R:36, G:36, B:36)	220 x 180 x 75mm	1.66kg
SP-64	30W	25°	10mm Ø	153 (R:51, G:51, B:51)	200 x 280 x 100mm	1.8kg
SP-5W	30W	120-130°	5mm Ø	381 (R:127, G:127, B:127)	200 x 280 x 100mm	1.8kg
SP-HP	45W	25-30°	1W	36 (R:12, G:12, B:12)	248 x 212 x 120mm	2.1kg
SP-T8	40W	45°	3 in 1 3W Tri colour	8 x 3W Tri colour	248 x 212 x 120mm	2.1kg
SP-UV	30W	25°	10mm Ø	168 UV LEDs	200 x 280 x 100mm	1.8kg
SP-W1	30W	25°	10mm Ø	168 White LEDs (8000k)	200 x 280 x 100mm	1.8kg
SP-W2	30W	125°	5mm Ø	381 White LEDs (8000k)	200 x 280 x 100mm	1.8kg

Note: Conforms to Laser and LED Safety standard BSEN60825-1:2007

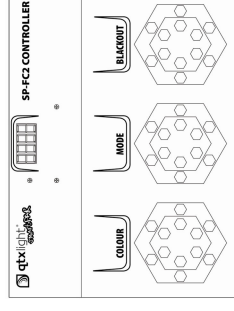
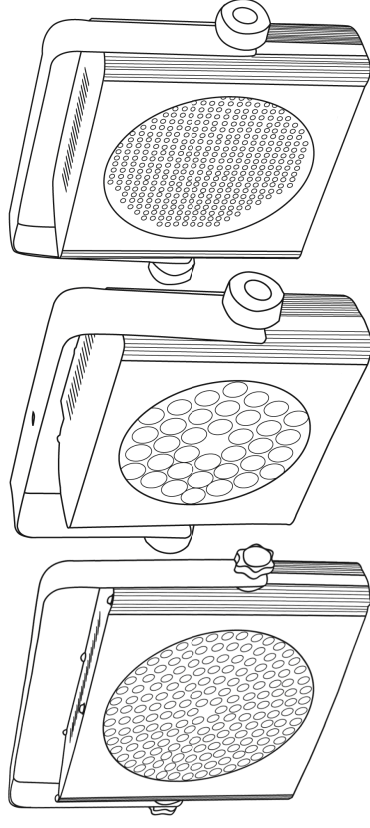

Manual copyright protected by QTX Light



**User manual for SmartPAR**

For Models: SP-36, SP-56, SP-64, SP-SW, SP-HP, SP-T8, SP-UV, SP-W1, SP-W2

Version 1.0

**LED SMARTPAR PAR CANS: For indoor use only**



**CAUTION! Please read this manual carefully before operating! Pay special attention to Sections 3 & 5 of this document.**

**1. General introduction :**

The QTX Light SmartPAR family of LED Par cans have been designed for a variety of applications, whether you're a mobile DJ, a band/singer, a bar/nightclub, theater company or production company then these par cans have everything you need and are simple and easy to use. There are 9 different models (see below) each has different purpose and functions all of which are fully explained in this manual. Please read below for more information:

- SP-36, SP-56: RGB LED designed based on traditional PAR cans. There is a & SP-64 36, 56 and 64 all spot type light effect with RGB colour mixing
- SP-HP: 36 x 1W High power RGB LED – Spot type light effect but the High power LEDs can travel a longer distance and cover a larger area than the above model.
- SP-SW: 381 RGB LED Stage wash – Designed to give a colour wash with a 120°-130° spread.

SP-T8: 8 x 3 in 1 3W Tri colour LEDs in a small housing designed for



**14. DMX controlling:**

**RGB Items 4 Channel DMX**

Channel	Function
1	Red 0-100% Dimming
2	Green 0-100% Dimming
3	Blue 0-100% Dimming
4	000-007 Closed
	008-190 Dimming 0-100%
	191-200 Sound activated
	201-247 Strobe
	248-255 Open 100%

**UV and White version 1 Channel DMX**

Channel	Function
1	000-007 Closed
	008-190 Dimming 0-100%
	191-200 Sound to light pulse
	196-200 Sound to light strobe
	201-247 Strobe
	248-255 Open 100%



the best colour mixing and ideal for highlighting fixtures and fittings.

**Code Description (UV and White Versions):**

A001 - A512	DMX-512 Address from 1 to 512
Er_L	If there is a breakdown in the DMX connection
AUTO	Auto Fade in and fade out
SOU1	Sound to light strobe
SOU2	Sound to light pulse strobe
L 25	Brightness = 25% of full potential
L 50	Brightness = 50% of full potential
L 75	Brightness = 75% of full potential
L100	Brightness = 100% of full potential

**13. Connection the SP-FC2 Foot controller:**

The SP-36, SP-56, SP-64, SP-SW, SP-HP and SP-T8 items can all be operated by the SmartPAR foot controller.

The cable for connecting and powering the foot controller is provided in the box with the SP-FC2. Connect as shown below and when setting the addressed set in following order so the chase programs can operate correctly.

Connecting in 4's

1<sup>st</sup> Par can = A001

2<sup>nd</sup> Par can = A005

3<sup>rd</sup> Par can = A009

4<sup>th</sup> Par can = A013

Repeat or reverse depending on the effect you desire when connecting more.

SP-UV: UV LED – Designed to replace the traditional UV spot canon.

SP-W1: White LED – Designed to be used as a Spot light or a strobe.

SP-W2: To be used as a white stage wash or wide angle strobe light.

Foot controller:

The five RGB models SP-36, SP-56, SP-64, SP-SW, SP-HP, SP-T8 have remote control sockets on the rear. All these models can be used by the QTX Light SP-FC-2 foot controller and can be used in combination with each other by master and slave. (see section 13)

We recommend that all these products is used within the guidelines HSG95

**2. Package contents:**

Please check the contents to ensure that the product has been received in good condition.

Light x 1 unit	User's Guide x 1 pcs
IEC UK Power Lead x 1	IEC EU Power Lead x 1

If you find any accessory is missing or the lighting has arrived with any problems, please contact your local dealer at once. This product contains no serviceable parts to make no attempt to try to fix or modify this item yourself as you may invalidate the warranty. We recommend you keep the original package and proof of purchase for any possible replacement or returned demand.

**3. Installation :**

This product is for professional use only and every person involved with the installation, operation and maintenance of this device should be qualified and follow the instructions of this User Guide. We recommend that this product is not used for audience scanning and should be used within the guidelines of radiation of lasers used for display purposes "HSG95". (copies of the guidance can be downloaded from the HSE website

<http://www.hse.gov.uk/pubns/priced/hsg95.pdf>

When you connect to the main power supply the device will illuminate and the light effect will change with music when in sound activated mode.



**Code Description (RGB Versions):**

A001	DMX-512 Address from 1 to 512
-	
A512	
Er_L	If there is a breakdown in the DMX connection
AUT1	Auto colour change: Red - Green - Blue - Red + Green - Red + Blue - Blue + Green - Red + Green + Blue repeat
AUT2	According to AUT1 colour sequence to display colour changer, fade in & fade out (Slow fade in - slow fade out)
AUT3	According to AUT1 colour sequence to display colour changer, fade in & fade out (Slow fade in - quick colour change)
AUT4	RGB Mixing & random colour selection to display colour change & fade in effect
AUT5	Fixed colour mixing, quickly colour changer & fade in effect
SOU1	According to AUTO5 colour sequence to display sound activated + colour mixing
SOU2	According to AUTO5 colour sequence to display sound activated + strobe + colour mixing
SOU3	According to AUTO5 colour sequence to display sound activated + colour mixing + strobe
SOU4	According to AUTO5 colour sequence to display according to AUT1 colour sequence to display sound activated.



**12. Functions guide:**

**Button operation (from left to right):**

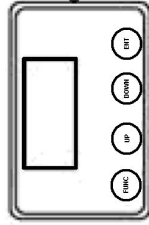

FUNC	Function
UP	Up
DOWN	Down
ENT	Enter

**Code illustration:**

SOU	= Sound to light mode
AUT	= Auto mode
A001	= DMX Address (1 - 512)
COL	= Manual colour select
L	= Brightness (UV and White Version)

Press the "FUNC" button. Use "UP" & "DOWN" to select the option. Press "ENT" to confirm the function you require, then press "UP" & "DOWN" again until you reach the desired option. Press "ENT" to confirm.

When selecting a DMX address press and hold "UP" or "DOWN" for quick speed scanning of the address. Press "ENT" to confirm.



**4. Mounting instruction :**

The fixture may be mounted in any position provided there is adequate room for ventilation. It is important never to obstruct the fan or vent pathway. Mount the fixture using a clamp. Unscrew the safety screws underneath the device and fix a G-Clamp to the fixture. After finding desired position tighten the G-Clamp. When selecting installation location, take into consideration routine maintenance. Safety cables must always be used. Never mount in places where the fixture will be exposed to rain, high humidity, extreme temperatures changes or restricted ventilation. The product should be securely mounted so that its output emission is always directed away from people and at objects that are able to reflect emission in a hazardous direction. In this regard, the separation distances cited in HS(G)95 should be observed.

**5. Caution :**

For your safety, please kindly pay attention to all of the warnings below:

- Always plug in the power plug last and disconnect from the mains, when the device is not in use or before cleaning.
- Do not install and operate the device in rain or extreme heat, moisture or dusty environments.
- This device is for indoor use only and in a dry environment.
- Do not switch on immediately but wait until it reaches room temperature, if the device has been exposed to drastic temperature fluctuations.
- Do not shake the device and avoid brute force when installing or operating



- Do not use the device during thunderstorms and please disconnect the power.
- Do not use solvents or aggressive detergent to clean the device. Use a soft and clean cloth.
- Do not modify the device or the connected power cord without authorization.
- Use appropriate safety-ropes.
- Do not stare into the light, this product emits hazardous levels of optical radiation and will cause serious injury to the eyes if viewed at close range.
- This product should be securely mounted so that its output emission is always directed away from people and at objects that are able to reflect emission in a hazardous direction. In this regard, the separation distances cited in HS(G)95 should be observed.
- The symbol  determines the minimum distance from lighted objects. The minimum distance between light-output and the illuminated surface must be more than 0.5m.

**1.1. General rear display:**

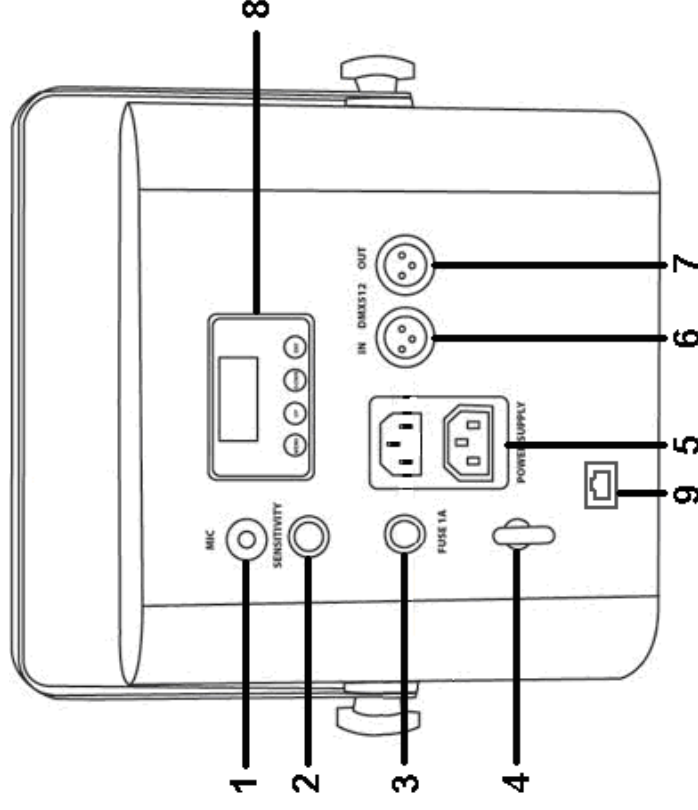

1. Microphone
2. Sound sensitivity control
3. Fuse holder
4. Safety hook
5. Power supply
6. DMX IN
7. DMX OUT
8. Digital controller
9. Remote control connection (RGB versions)

**10. General layout:**

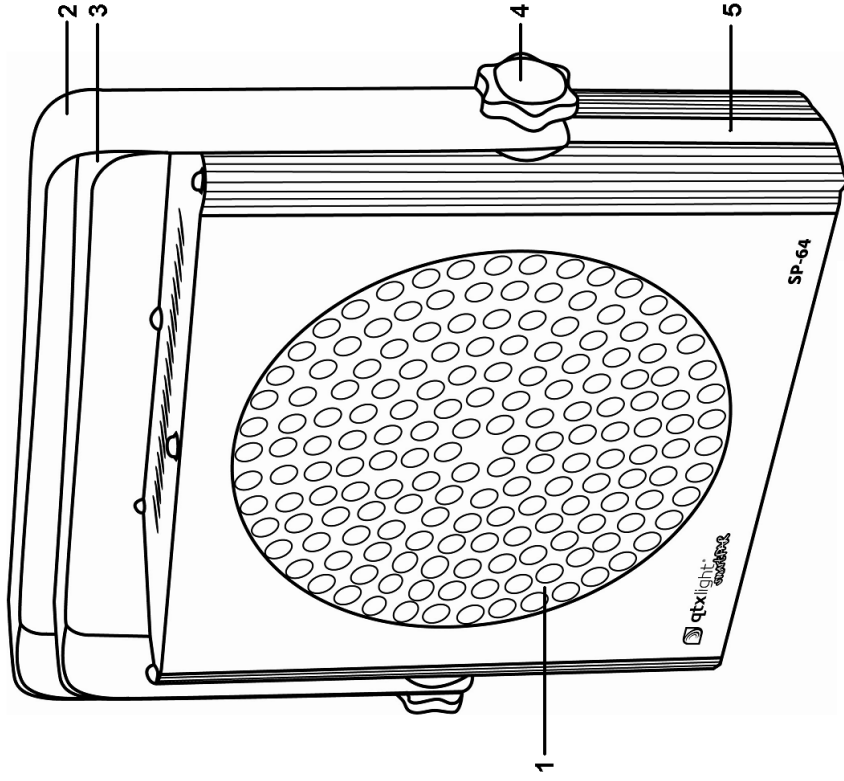

1. Lens covering LEDs
2. Mounting bracket
3. 2<sup>nd</sup> Mounting bracket
4. Thumb screw
5. Housing cover

**6. Connect with power supply:**

Use the plug to connect to the main power supply as following.

Line	Connection	International signal
Brown	Live	L
Blue	Neutral	N
Yellow /Green	Earth	E

**7. Replacing fuse :**

Disconnect from the main power supply first, then remove the fuse from the IEC Socket or fuse holder . Replace with a fuse of the correct rating as stated on product label or user guide.

**8. General maintenance:**

To maintain optimum performance and minimize wear, fixtures should be cleaned frequently. Usage and environment are contributing factors in determining frequency. As a general rule, fixtures should be cleaned at least twice a month. Dust build-up reduces light output performance and can cause overheating. This can lead to reduced lamp life and increased mechanical wear. Be sure to power off fixture before conducting maintenance. Unplug fixture from power. Use a vacuum or air compressor and a soft brush to remove dust collected on external vents and internal components. Clean all glass when fixture is cold with a mild solution to the cloth or tissue, and drag dirt and grime to the outside of the lens. Gently polish optical surface until they free of haze and lint.

The cleaning of internal and external optical lenses and/or mirrors must be carried out periodically to optimize light output. Cleaning frequently depends on the environment in which the fixture operates: damp, smoky or particularly dirty surroundings can require cleaning fluid. Always dry the parts carefully. Clean the external optics at least every 20 days.



**9. Quick trouble shooting :**

7.1 If the unit does not function – Check that the main power is on and the fuse is intact.

7.2 If the unit is not reacting to music – check the unit is in “sound to light” mode and that the sensitivity control is fully clockwise.

7.3 If the product is not reacting to DMX signals, check the cables and connections

