

KNS SERIES

PROFESSIONAL HEADPHONES



KNS6400

KNS8400



USER MANUAL

CONTENTS

Your carton should contain the following items:

User manual (this document)
KNS-6400 or KNS-8400 headphones
Connection cable, with screw-in adaptor (fitted)
Protective soft bag
Anti-Microbial/Bacterial cleaning cloth

KNS-8400 type contains an additional in-line volume control

REGULATORY CERTIFICATION

KRK declare under our sole responsibility that this product, to which this declaration relates, is in conformity with the following standards:



REACH

The Declaration of Conformity can be obtained from:
382 Ave. de la Couronne, B-1050 Brussels

Authorized European representative:
Phone: +3226450500
Fax: +326450505



WARNING: This product contains a chemical known to the State of California to cause cancer and birth defects or other reproductive harm.

SAFETY

The possible results of incorrect use are marked by one of the two symbols “WARNING” and “CAUTION”, depending on the imminence of the danger and the severity of the damage.



WARNING: Ignoring these warnings may cause severe injury or death as a result of incorrect operation.



CAUTION: Ignoring these cautions may cause moderate injury or damage as a result of incorrect operation.



NOTE: This advice ensures you continue to get the best long term performance from your headphones.



WARNING: If water or other foreign objects enter the inside of the device, fire or electric shock may result.



WARNING: Do not attempt to disassemble or modify this product. Doing so could result in personal injury and / or product failure.



WARNING: Do not use mobile phone adaptors to connect headphones to the jack sockets on airplane seats. This can cause overheating possibly resulting in personal injury such as burns, et



WARNING: Do not use headphones when driving or operating any kind of mechanized transport. Safety of yourself and pedestrians is put at risk as you are prevented from hearing external warning noises.



CAUTION: The character of external warning sounds can be affected during headphone use. Ensure you can still recognize these sounds before use.



CAUTION: Do not subject headphones to extreme force such as dropping, impact from another object, or impact from poorly packed luggage.



CAUTION: Do not pull, or put excessive strain on the headphone cable, this may cause damage and /or failure.



CAUTION: Keep the product dry and avoid exposure to extreme temperatures and humidity.



CAUTION: Ensure the headphone plug is securely being held when disconnecting the cable; never pull on the cable as this could cause damage to the connections.



NOTE: It is common for the headphone ear cushions to gradually deteriorate over time; this is commonly known as “wear and tear”.

SAFETY LISTENING GUIDANCE



WARNING: LISTENING TO AUDIO AT EXCESSIVE VOLUMES CAN CAUSE PERMANENT HEARING DAMAGE. USE AS LOW A VOLUME AS POSSIBLE.

Over exposure to excessive sound levels can damage your ears resulting in permanent noise-induced hearing loss (**NIHL**). Please use the following guidelines established by the Occupational Safety Health Administration (**OSHA**) on maximum time exposure to sound pressure levels before hearing damage occurs.

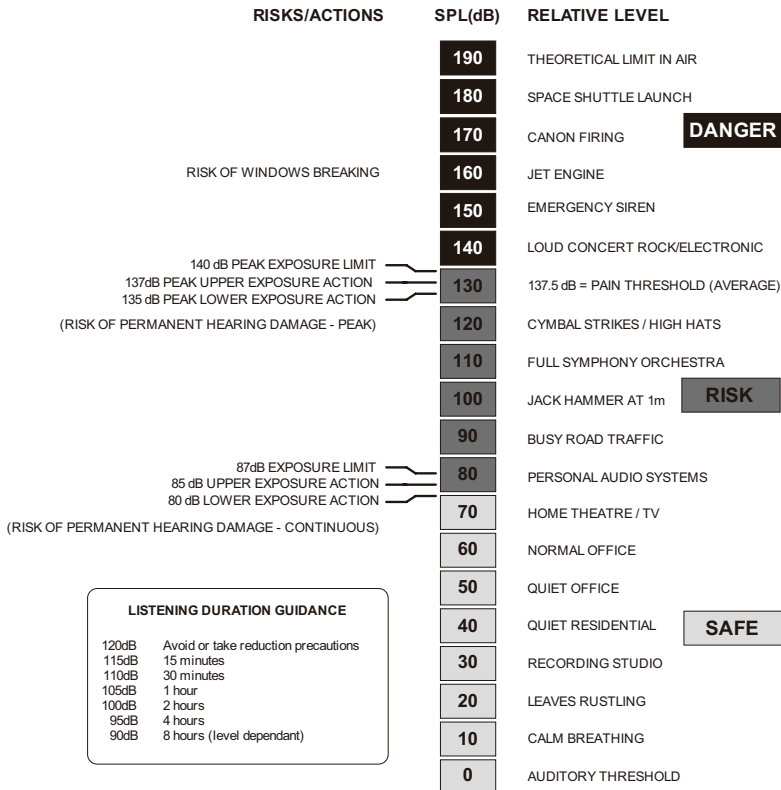

WARRANTY

Please refer to the warranty card shipped with your product. Please also fill in the attached registration card if you'd like us to keep you up to date on KRK developments.

DISPOSAL

This symbol on the product, in the instructions or on the packaging means that your electrical and electronic equipment should be disposed at the end of its life separately from your household waste. There are separate collection systems for recycling in the EU. For more information, please contact the local authority or your retailer where you purchased the product.

This product's packaging materials are recyclable and can be reused. We advise keeping the packaging for shipping, but if you choose to dispose of it, please do so in accordance with your local authorities regulations.

CARE AND MAINTENANCE

KNS Series headphones do not require a service schedule. Please follow the cautions below when cleaning your product.



CAUTION: Only use the provided anti-microbial/bacterial cloth to clean your headphones; this will help maintain good hygiene.



CAUTION: Never use solvents or thinners to clean the headphones, this can damage the headphones.



CAUTION: If the headphones become excessively dirty wipe down with a slightly damp non-abrasive cloth, then dry immediately.



CAUTION: While cleaning your headphones, please avoid getting liquid and/or foreign objects in the driver ports, volume control and connections.

WELCOME

Congratulations on your choice of headphones, and welcome to the ever growing family of KRK owners.

KRK's KNS Series of professional studio headphones are designed to forever change the way you handle your most demanding audio jobs.

The KNS headphones feature key design elements that continue to make the KRK sound a "studio standard". The series was created using stringent design philosophies applied to all of our products.

The result is a studio reference set of headphones that you can trust, delivering defined low-end, articulate midrange, and precise, natural highs.

Whether you are making critical mixing decisions or need to capture the subtle nuances of a unique sound, you'll quickly discover that the KNS Series deliver a new level of audio performance.

This manual is intended to inform you of the many features of your new KNS headphones. We encourage you to take a few minutes to familiarize yourself with this manual.

Thank you once again for choosing KRK!

USAGE GUIDANCE

The KNS series headphones are designed for critical listening and monitoring in the following situations:

Engineer/Artist Recording Studio: Mixing / Monitoring / Recording

Engineer/Artist Broadcast Studio: Mixing / Monitoring / Recording

Musician/Artist Studio: Monitoring / Composition / Recording

Musician/Artist Live/Stage, Monitoring

Technician Monitoring at any location

General Personal music listening

DESIGN PHILOSOPHY

Any studio monitor is a tool used to aurally “measure” the changes in an audio path. Ask any seasoned recording professional what they think makes a great monitor and you’ll get the same consistent answers: “Accuracy, transparency, flat response, and the truth.”

From years of listening to feedback from some of the top engineers and producers, the KRK design team has an in-depth understanding how a properly tuned monitor is a critically important recording tool.

The KNS series headphones are designed, engineered and tuned to the same exacting standards and have been developed to be as flat as possible so that what you hear represents the true nature of the audio material without coloration or enhancement.

Using professional monitors in an acoustically correct studio is ideal for recording, mixing and mastering – but there are times when portability, sound isolation and freedom from your environment’s acoustic limitations are the priority.

The KNS Series from KRK is becoming the headphone of choice for mix analysis. After all, hearing what is wrong with your mix is just as important as hearing what is right! At KRK, our passion is monitoring and accurately reproducing a natural, honest sound everywhere in the control room, the KNS series are no exception.

Whether you are mixing tracks, or recording your next song, the KNS series gives you the famous KRK sound independent of your monitors. This closed-back around-the-ear design brings you closer to your music, and the highly isolated memory foam ear cushions provide incredible isolation and long term comfort.

Having “One Voice” that consistently gives you an accurate reproduction of your music or mix will help you to achieve just what the artist intended.

Especially when the artist is you!

FEATURES

- Voiced to remain true to the character of KRK's class leading studio monitors, developed with 25 years of years of experience in studio sound.
- The latest reference quality frequency response for closed-back, circum-aural dynamic headphones.
- Newly developed headphone acoustical system bringing a new level of headphone performance for the first time.
- Utilizing the latest in acoustic memory foam technology ensures class leading performance in both reproduction and isolation.
- A new standard in headphone comfort, even over extended periods of use, designed to avoid feeling uncomfortable especially during long periods of use. The special foam conforms to the ear to help ensure an improved fit.
- Exceedingly accurate, natural and wide frequency response
- Large dynamic range with extremely consistent low-distortion detail and clarity.
- Extended low frequency definition, ensures the bass component of your music is accurately reproduced, and is not lost.
- Transparent reproduction of high-frequencies, resulting in highly accurate imaging.
- Designed to last, made from durable, impact resistant materials throughout the system.
- Designed in California, made in Taiwan.

FEATURES

- High-efficiency Neodymium 40mm driver
- High durability 2.5m single-sided straight cable with oxygen-free copper wires
- KNS-8400 comes with a replaceable in-line volume control with a sleek profile which is designed not to catch on clothing or instruments during performance. The volume control also uses a high quality long-life fader and comes in a sturdy enclosure.
- Adjustable, foldable driver enclosures provide comfort and portability
- Replacable cable, head, and ear cushions to ensure long product life
- Soft carrying case embossed with the KRK logo for travelling engineers, or storage when not in use.
- ¼" jack plug can be unscrewed to reveal a 1/8" plug for laptops and portable media players.
- Anti microbial/bacterial cleaning cloth
- User instructions and warranty

SPECIFICATIONS

System / Design

Dynamic

Operating System

Closed-back

Head Coupling

Circumaural (Isolating)

Voice Coil

Copper-clad aluminum wire

Driver Type

Low weight neodymium

Driver Diameter

40mm

Sensitivity/Efficiency

[KNS-6400] 95dB SPL @1mW

[KNS-8400] 97 dB SPL @1mW

Frequency Response

[KNS-6400] 10Hz-22 kHz

[KNS-8400] 5Hz-23 kHz

Total Harmonic Distortion

< 0.1%

Rated Impedance

36 ohms

Ambient Noise Isolation

[KNS-6400] up to 26 dBA

[KNS-8400] up to 30 dBA

Long Term Maximum Power Handling

1000mW

(500mW per side as per IEC 60268-7)

Earcup Rotation

90 degrees

Nominal Headband Pressure

4 N (based on average head size)

Headband Type

Adjustable / Sprung steel skeleton

Ear Cushion type

Acoustic cellular foam [KNS-6400]

Acoustic memory foam [KNS-8400]

Headpad Finish

Leatherette [KNS-6400]

Premium leatherette [KNS-8400]

Headphone Finish

Black impact resistant plastic

Cable

2.5 m, (8.2 ft.), 99,99% OFC detachable

Connector

Gold-plated stereo 1/8" (3.5 mm)

Cable Connection

Strain relief managed

Adaptor

Screw-on 1/4" (6.3 mm)

Weight without Cable

[KNS-6400] 202 g (0.44lbs)

[KNS-8400] 232 g (0.51 lbs)

Net / Shipping Weight

[KNS-6400] 820 g (1.8 lbs)

[KNS-8400] 850 g (1.87 lbs)

Dimensions

245mm x 268mm x 94mm

9.6" x 10.5" x 3.7"

* For improvement purposes, specifications and design are subject to change without notice.

ACCESSORIES AND PART NUMBERS

Part Numbers:

KNS-6400	KNS 6400 HEADPHONE
KNS-8400	KNS 8400 HEADPHONE
CUSK00001	CUSHION EAR KNS6400
CUSK00002	CUSHION HEAD KNS6400
CUSK00003	CUSHION EAR KNS8400
CUSK00004	CUSHION HEAD KNS8400
CBLK00027	CABLE COILED 2.5 M KNS
CBLK00028	CABLE STRAIGHT 2.5 M KNS
CBLK00029	CABLE STRAIGHT 3M EXTENSION KNS
CBLK00030	CABLE STRAIGHT 10M EXTENSION KNS
CBLK00031	VOLUME CONTROL KNS
CBLK00032	CABLE STRAIGHT 1.5 M KNS
BAGK00009	BAG PROTECTIVE KNS
CONK00007	CONNECTOR 1/8" to 1/4" ADAPTER KNS

Replacement parts and accessories:

Accessories or replacement parts can be ordered through KRK Customer Service / Sales. Please see the contact information on the final page of this document for contacts in your territory.

WEARING/ADJUSTING GUIDE

Place the headphones on the head guided by the markings which identify the left and right driver enclosures. Adjust the headband as shown below so it rests gently on top of your head and the ear cushions fit comfortably around your ears. The driver enclosure is connected using an adjustable yoke which will naturally turn to ensure proper fitting, and optimum performance. There should not be excessive pressure when the headband is adjusted correctly.

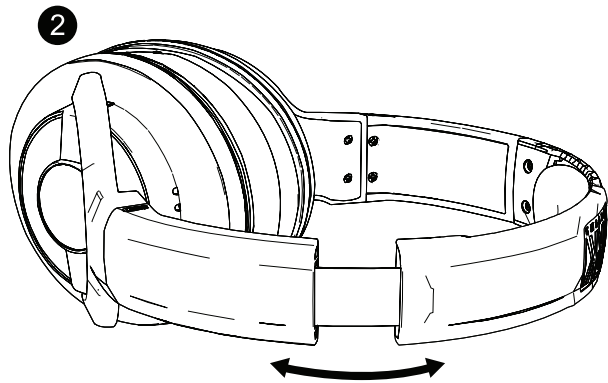
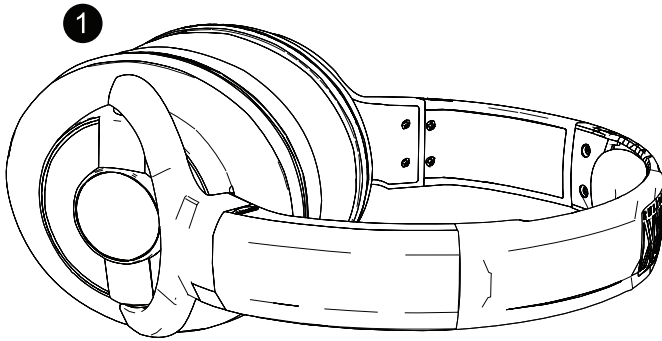

CONNECTING

The KRK KNS series headphones connect with almost any professional and consumer audio device such as Professional Live, Recording and Broadcast Mixers, Audio Interfaces, Headphone Amplifiers, personal computers, personal media players, CD/DVD/Blu-Ray players.

Most professional audio equipment utilizes a 1/4" socket for connection of headphones. In this instance, the headphones are ready to use as supplied with the 1/4 screw-in adapter fitted.

Personal computers, media players and some consumer devices utilize an 1/8" socket for connection of headphones. In this instance, please un-screw the 1/4 adapter from the tip of the cable to reveal the 1/8" connection. Please remember to store the adaptor safely so that it can be used when necessary.

Insert the headphone plug securely into the audio jack of the selected audio device.



NOTE: KRK recommends turning off all sound enhancements / special effects present in some consumer devices before use. This processing can prevent you from getting the best performance from your headphones.



WARNING: The KNS headphones when driven by high-powered headphone amplifiers have the capability to reproduce audio at levels which can damage hearing over time. Please ensure good care when connecting, setting up, and using your headphones. Keep in mind that your ears are the most important tool of your trade, please treat them accordingly.



WARNING: When plugging your headphones into a headphone amplifier, please make sure that the level control on the amplifier / mixer / audio interface is set to minimum and slowly raised to the required operating level.

CABLE CONNECTION GUIDE

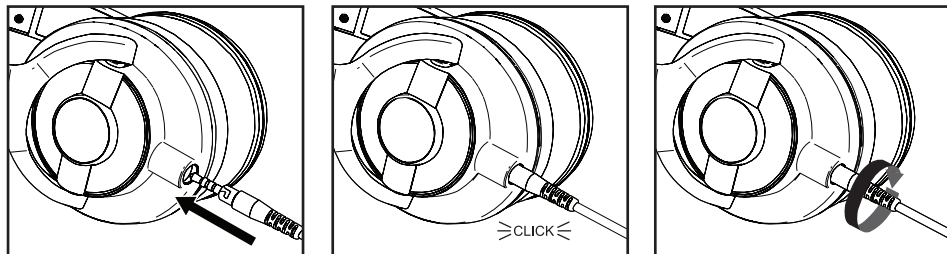

1. Insert 1/8" connector into socket (from cable or headphone volume control)
2. When properly inserted you will feel it "click" into place.
3. Now turn the plug clockwise in the socket to secure the cable

VOLUME CONTROL CONNECTION GUIDE



CUSHION REMOVAL/FITTING GUIDE

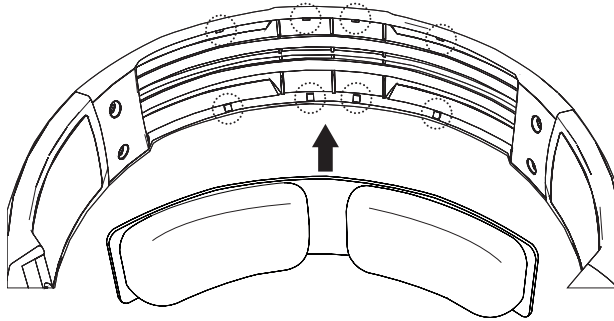

REPLACING THE HEAD CUSHION

The head cushion is held in place by a mounting flange which snaps under small tabs located around the inside rim of the headband. If a head cushion becomes loose, simply push the mounting flange of the earcup cushion back into the earcup. Using your finger or thumb, press around the edge of the mounting flange, making sure it “snaps” in place all the way around the head cushion.

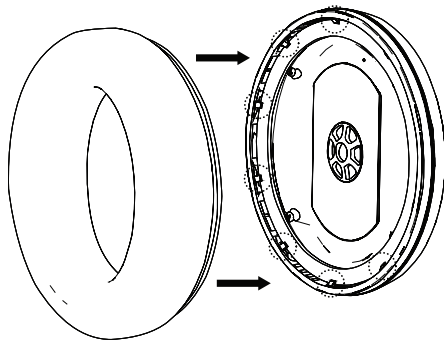

REPLACING THE EAR CUSHIONS

The ear cushions are held in place by a mounting flange which snaps under small tabs located around the inside rim of the driver enclosure. If an ear cushion becomes loose, simply push the mounting flange of the ear cushion back into the driver enclosure. Using your finger or thumb, press around the edge of the mounting flange, making sure it snaps in place all the way around the ear cushion.

STORAGE AND PROTECTION

To ensure your headphones are well protected during travel there is a specially designed soft bag included in the package.

Please ensure the headphones are fitted into the bag as shown below and that it is tied securely to prevent anything from entering the bag which could cause damage.

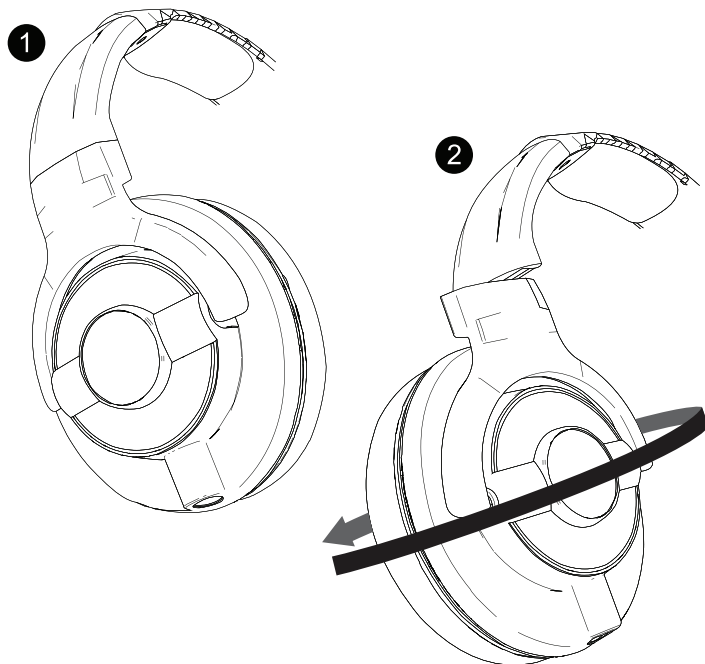

TROUBLESHOOTING

Problem	What to do
No audio	Ensure your device is plugged in correctly Ensure your device is connected to the correct socket Ensure the source is sending audio and the output level is good.
Excessive bass	Turn off any bass boost features on the source device
Distorted bass	Make sure that the driver enclosure ports are not blocked, if they become blocked, please clean as directed.
Distorted sound	Ensure that the driver enclosure ports are not blocked, if they become blocked, please clean as directed

If any problem persists, contact Customer Service. See the phone number for your area included in this guide.

CONTACT DETAILS

POSTAL:

KRK Systems, LLC.
772 S. Military Trail
Deerfield Beach, FL 33442

WEB:

www.krksys.com

SALES

EMAIL:

salesorders@krksys.com

TELEPHONE:

+1 954-949-9600, option 1

FAX:

+1 954-949-9590

CUSTOMER SUPPORT

EMAIL:

service@krksys.com

TELEPHONE:

+1 954-949-9600, option 3

FAX:

+1 954-949-9590

REPAIRS/RETURNS

EMAIL:

returns@krksys.com

TELEPHONE:

+1 954-949-9600, option 2

FAX:

+1 954-949-9590

MARKETING COMMUNICATIONS:

marketing@krksys.com

HUMAN RESOURCES:

hr-staffing@krksys.com

*Please provide your phone number with your contact e-mail message.

