





NOTES:

1. SYMBOL  INDICATES MOUNTING POINT, 3/8-16 THREADED HOLE (RIVNUT).
2. SYMBOL  INDICATES MOUNTING POINT, 3/8-16 THREADED HOLE (NUT PLATE).
3. SYMBOL  INDICATES RUBBER FOOT.
4. SYMBOL  INDICATES CENTER OF BALANCE.
5. WEIGHT APPROX. 43 LBS.
6. SHIPPING WEIGHT APPROX. 51 LBS.

REV	DESCRIPTION	APVD/DATE
1	REVISED PER ECO #4923 DM 10/11/00.	KFH 10/13/00

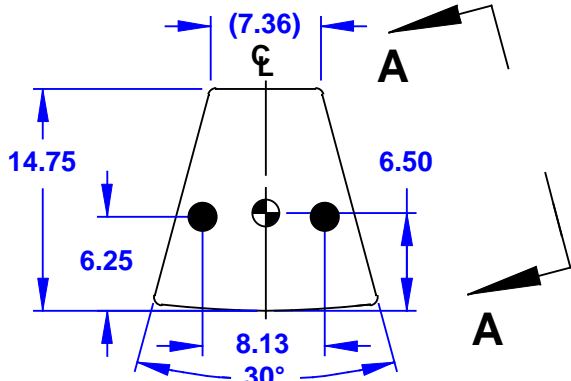

TOP

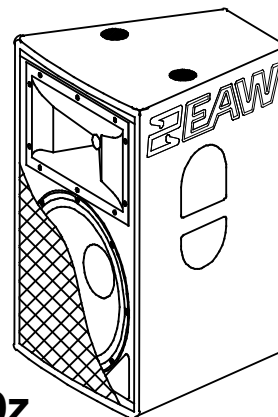

FR129z

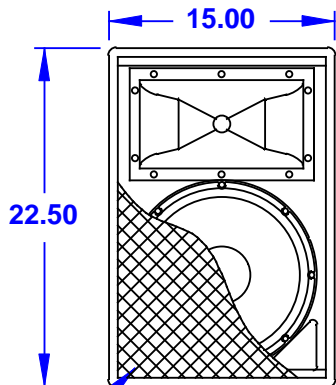

FRONT

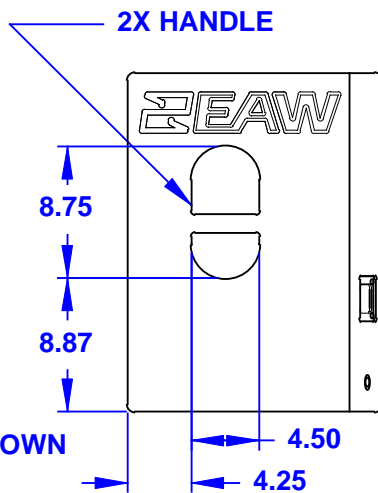

VIEW A-A
DIMENSIONS APPLY TO BOTH SIDES

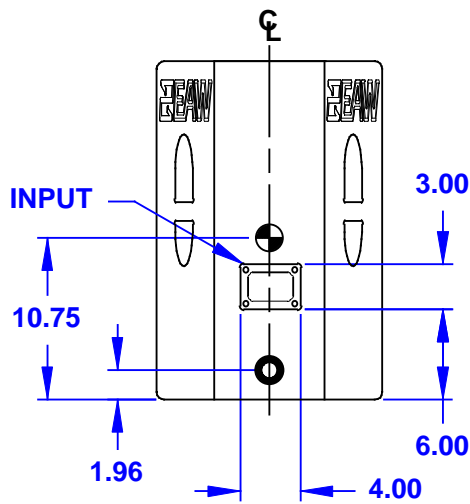

BACK

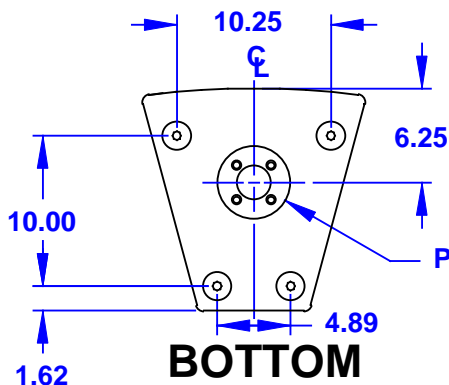

BOTTOM

DOCUMENT CONTROL PER SPECIFICATION 4.5.201

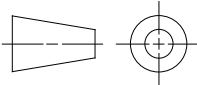
<p>THIRD ANGLE PROJECTION</p> 	<p>UNLESS OTHERWISE SPECIFIED: ALL DIMENSIONS ARE IN INCHES</p> <p>TOLERANCE IN INCHES .XX ± .13 ANGLES ± 1°</p> <p>(X.XX) = REF DIMS NO TOLERANCE IMPLIED</p> <p>T.S.C.=THEORETICAL SHARP CORNER</p> <p>DIMENSIONS ACROSS CENTERLINES TO BE SYMMETRICAL</p>	<p>STATUS: PRODCUTION</p>		<p>EAW EASTERN ACOUSTIC WORKS ONE MAIN STREET WHITINSVILLE, MA 01588 USA</p>	
		<p>APPROVALS</p> <p>DRAWN: MFL 7/15/99</p> <p>CHECKED: FEL 3/29/00</p> <p>DES ENG: RJM 3/31/00</p> <p>MFG ENG: DBD 4/3/00</p>	<p>DATE</p>		<p>TITLE: CABINET/FINISHED/FR129z [MECHANICAL SPECIFICATION]</p>
<p>THIS DRAWING IS THE PROPERTY OF EAW AND SHALL NOT BE COPIED, REPRODUCED, OR USED AS THE BASIS FOR MANUFACTURE OR SALE OF APPARATUS WITHOUT WRITTEN AUTHORIZATION. DO NOT SCALE DRAWING.</p>		<p>A SHEET 1 OF 1</p>	<p>SCALE: 1 TO 12</p>	<p>DRAWING NUMBER: 510939</p>	<p>REVISION: 1</p>