

KAM

L I G H T I N G

Professional Lighting Solutions

LED800 S

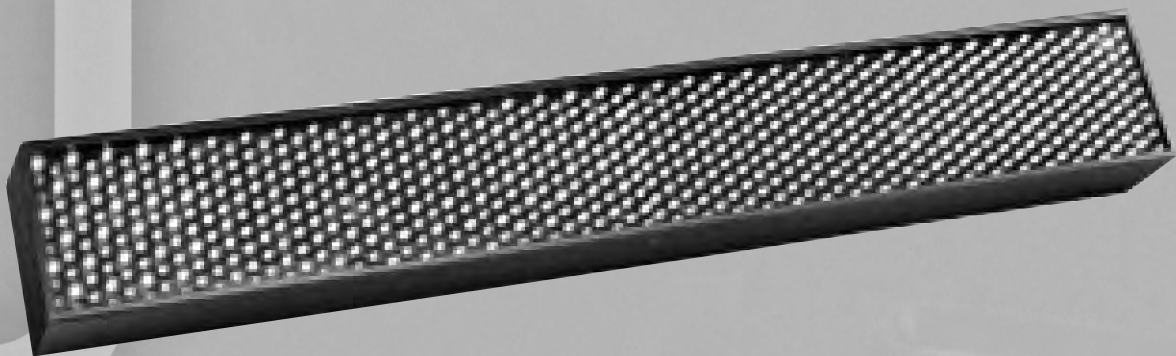

PRODUCT MANUAL

www.kam.co.uk

TABLE OF CONTENT

INTRODUCTION.....	1
SAFETY INSTRUCTIONS	1
OPERATING INSTRUCTIONS.....	2
OVERVIEW	2
INSTALLATION	2
OVERHEAD RIGGING	2
OPERATION	3
INITIALIZATION	3
LCD MENU SEQUENCE.....	3
ADDRESSING	4
LED BRIGHTNESS ADJUSTMENT.....	4
NON DMX RUNNING MODES.....	4
CHASE	4
DMX MODE: GROUP.....	4
DMX MODE: CHANNEL	5
COMBINATIONS OF GROUP MODE AND CHANNEL MODE.....	6
MASTER-SLAVE RUNNING MODE	7
CLEANING AND MAINTENANCE	7
REPLACING THE FUSE	7
TECHNICAL SPECIFICATIONS.....	8



CAUTION!
KEEP THIS DEVICE AWAY FROM RAIN AND MOISTURE!
UNPLUG MAINS LEAD BEFORE CARRYING OUT AND REPAIRS OR
SERVICING.

FOR YOUR OWN SAFETY, PLEASE READ THIS USER MANUAL CAREFULLY BEFORE USING THIS UNIT.

EVERY PERSON INVOLVED WITH THE INSTALLATION, OPERATION AND MAINTENANCE OF THIS DEVICE HAS TO

- BE QUALIFIED
- FOLLOW THE INSTRUCTIONS OF THIS MANUAL
- CONSIDER THIS MANUAL TO BE PART OF THE TOTAL PRODUCT
- KEEP THIS MANUAL FOR THE ENTIRE SERVICE LIFE OF THE PRODUCT
- PASS THIS MANUAL ON TO EVERY FURTHER OWNER OR USER OF THE PRODUCT

INTRODUCTION

THANK YOU FOR HAVING CHOSEN KAM LED-800S INTELLIGENT LED COLOUR SYSTEM. IF YOU FOLLOW THE INSTRUCTIONS GIVEN IN THIS MANUAL, WE ARE SURE THAT YOU WILL ENJOY THIS DEVICE FOR MANY YEARS TO COME. THE LED-800S INTELLIGENT LED COLOUR SYSTEM FEATURES A BUILT-IN MICROPHONE.

UNPACK YOUR LED-800S INTELLIGENT LED COLOUR SYSTEM. BEFORE YOU INITIALLY START-UP, PLEASE MAKE SURE THAT THERE IS NO DAMAGE CAUSED BY TRANSPORTATION. SHOULD THERE BE ANY, CONSULT YOUR DEALER AND DO NOT USE THE DEVICE.

SAFETY INSTRUCTIONS



CAUTION!
BEWARE OF DANGEROUS VOLTAGE! RISK OF ELECTRIC SHOCK !!

THIS DEVICE HAS LEFT OUR PREMISES IN ABSOLUTELY PERFECT CONDITION. IN ORDER TO MAINTAIN THIS CONDITION AND TO ENSURE A SAFE OPERATION, IT IS ABSOLUTELY NECESSARY FOR THE USER TO FOLLOW THE SAFETY INSTRUCTIONS AND WARNING NOTES WRITTEN IN THIS USER MANUAL.

IF THE DEVICE HAS BEEN EXPOSED TO DRASTIC TEMPERATURE FLUCTUATION (E.G. AFTER TRANSPORTATION), DO NOT SWITCH IT ON IMMEDIATELY. THE ARISING CONDENSATION WATER MIGHT DAMAGE YOUR DEVICE. LEAVE THE DEVICE SWITCHED OFF UNTIL IT HAS REACHED ROOM TEMPERATURE.

PLEASE MAKE SURE THAT THERE ARE NO OBVIOUS TRANSPORT DAMAGES. SHOULD YOU NOTICE ANY DAMAGES ON THE A/C CONNECTION CABLE OR ON THE CASING DO NOT USE DEVICE CONSULT YOUR LOCAL DEALER.

ALWAYS PLUG IN THE POWER PLUG LAST. THE MAINS PLUG MUST ALWAYS BE INSERTED WITHOUT FORCE. MAKE SURE THAT THE PLUG IS TIGHTLY CONNECTED WITH THE POWER SOCKET.

NEVER LET THE POWER-CORD COME INTO CONTACT WITH OTHER CABLES! HANDLE THE POWER-CORD AND ALL CONNECTIONS WITH THE MAINS WITH PARTICULAR CAUTION! NEVER TOUCH THEM WITH WET HANDS, AS THIS COULD LEAD TO ELECTRICAL SHOCK.

NEVER MODIFY, BEND, STRAIN MECHANICALLY, PUT PRESSURE ON, PULL OR HEAT UP THE POWER CORD. NEVER OPERATE NEXT TO SOURCES OF HEAT OR COLD. DISREGARD CAN LEAD TO POWER CORD DAMAGE, FIRE OR ELECTRICAL SHOCK.

THE CABLE INSERT OR THE FEMALE PART IN THE DEVICE MUST NEVER BE STRAINED. THERE MUST ALWAYS BE SUFFICIENT CABLE TO THE DEVICE. OTHERWISE, THE CABLE MAY BE DAMAGED WHICH MAY LEAD TO DAMAGE, FIRE OR ELECTRICAL SHOCK.

MAKE SURE THAT THE POWER-CORD IS NEVER CRIMPED OR DAMAGED BY SHARP EDGES. CHECK THE DEVICE AND THE POWER-CORD FROM TIME TO TIME.

ALWAYS DISCONNECT FROM THE MAINS, WHEN THE DEVICE IS NOT IN USE OR BEFORE CLEANING IT. ONLY HANDLE THE POWER-CORD BY THE PLUG. NEVER PULL OUT THE PLUG BY TUGGING THE POWER-CORD. OTHERWISE, THE CABLE OR PLUG CAN BE DAMAGED LEADING TO ELECTRICAL SHOCK.

DURING THE INITIAL START-UP SOME SMOKE OR SMELL MAY ARISE. THIS IS A NORMAL PROCESS AND DOES NOT NECESSARILY MEAN THAT THE DEVICE IS DEFECTIVE.

OPERATING INSTRUCTIONS

THIS DEVICE IS DESIGNED FOR PROFESSIONAL USE, E.G. ON STAGES, IN DISCOTHEQUES, THEATRES ETC.

WHEN CHOOSING THE INSTALLATION-POINT, PLEASE MAKE SURE THAT THE DEVICE IS NOT EXPOSED TO EXTREME HEAT OR MOISTURE.

THIS DEVICE IS ONLY ALLOWED FOR AN INSTALLATION VIA THE MOUNTING BRACKET. IN ORDER TO SAFEGUARD SUFFICIENT VENTILATION, LEAVE 50 CM OF FREE SPACE AROUND THE DEVICE.

THE HOUSING MUST NEVER TOUCH SURROUNDING SURFACES OR OBJECTS..

ALWAYS FIX THE FIXTURE WITH AN APPROPRIATE SAFETY-CHAIN.

OPERATE THE DEVICE ONLY AFTER HAVING FAMILIARIZED YOURSELF WITH ITS FUNCTIONS. DO NOT PERMIT OPERATION BY PERSONS NOT QUALIFIED FOR OPERATING THE DEVICE. MOST DAMAGES ARE THE RESULT OF UNPROFESSIONAL OPERATION!

NEVER USE SOLVENTS OR AGGRESSIVE DETERGENTS IN ORDER TO CLEAN THE DEVICE! USE A SOFT AND DAMP CLOTH.

PLEASE USE THE ORIGINAL PACKAGING IF THE DEVICE IS TO BE TRANSPORTED.

PLEASE CONSIDER THAT UNAUTHORIZED MODIFICATIONS ON THE DEVICE ARE FORBIDDEN DUE TO SAFETY REASONS!

OVERVIEW

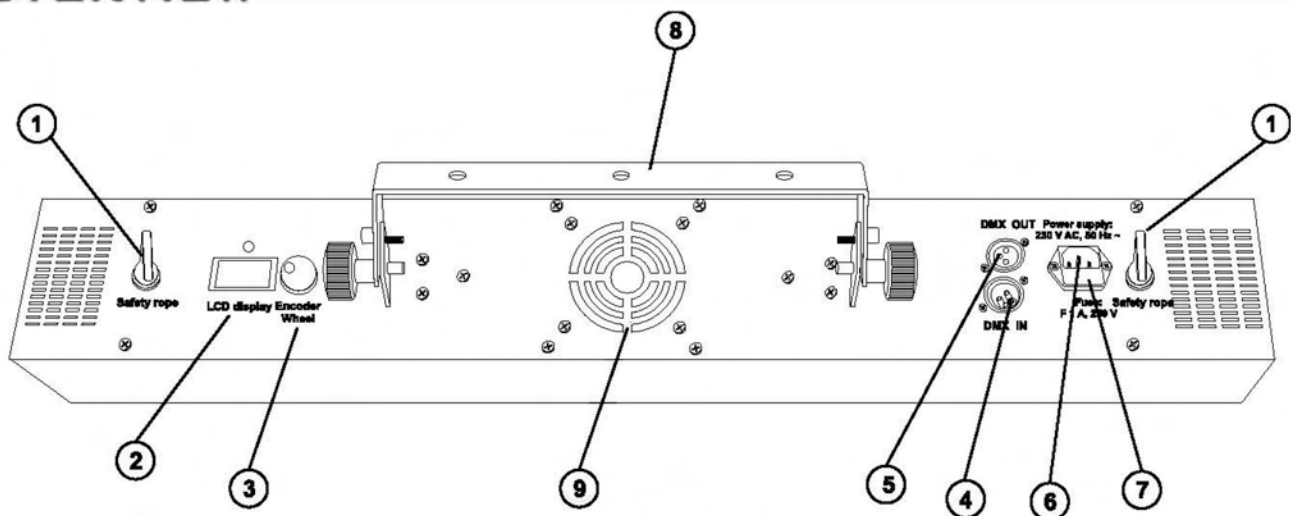

BACK

- 1. SAFETY ROPE EYELET
- 2. LCD DISPLAY
- 3. ENCODER WHEEL
- 4. DMX IN

- 5. DMX OUT
- 6. POWER SUPPLY
- 7. FUSE HOLDER
- 8. BRACKET
- 9. FAN

INSTALLATION

OVERHEAD RIGGING

THE INSTALLATION MUST ALWAYS BE SECURED WITH A SECONDARY SAFETY ATTACHMENT, E.G. AN APPROPRIATE SAFETY CHAIN. THIS SECONDARY SAFETY ATTACHMENT MUST BE CONSTRUCTED IN A WAY THAT NO PART OF THE INSTALLATION CAN FALL DOWN IF THE MAIN BRACKET FAILS.

PROCEDURE:

IMPORTANT! OVERHEAD RIGGING REQUIRES EXTENSIVE EXPERIENCE, INCLUDING (BUT NOT LIMITED TO) CALCULATING WORKING LOAD LIMITS, INSTALLATION MATERIAL BEING USED, AND PERIODIC SAFETY INSPECTION OF ALL INSTALLATION MATERIAL AND THE DEVICE. IF YOU LACK THESE QUALIFICATIONS, DO NOT ATTEMPT THE INSTALLATION YOURSELF, BUT INSTEAD USE A PROFESSIONAL STRUCTURAL RIGGER. IMPROPER INSTALLATION CAN RESULT IN BODILY INJURY AND OR DAMAGE TO PROPERTY.

THE DEVICE HAS TO BE INSTALLED OUT OF THE REACH OF PEOPLE.

	<p>DANGER OF FIRE! WHEN INSTALLING THE DEVICE, MAKE SURE THERE IS NO HIGHLY-INFLAMMABLE MATERIAL (DECORATION ARTICLES, ETC.) WITHIN A DISTANCE OF MIN. 0.5 M.</p>
---	--

MOUNT THE DEVICE TO YOUR TRUSSING SYSTEM USING AN APPROPRIATE CLAMP.

FOR OVERHEAD USE, ALWAYS INSTALL A SAFETY-CHAIN THAT CAN HOLD AT LEAST 12 TIMES THE WEIGHT OF THE FIXTURE PULL THE SAFETY-CHAIN THROUGH THE ATTACHMENT EYELET AND OVER THE TRUSSING SYSTEM OR A SAFE FIXATION POINT. THE MAXIMUM DROP DISTANCE MUST NEVER EXCEED 20 CM.

ADJUST THE DESIRED INCLINATION-ANGLE VIA THE MOUNTING-BRACKET AND TIGHTEN THE FIXATION SCREWS.

CONNECT THE FIXTURE TO THE MAINS WITH THE POWER-PLUG.

THE OCCUPATION OF THE CONNECTION-CABLES IS AS FOLLOWS:

CABLE	PIN	INTERNATIONAL
BROWN	LIVE	L
BLUE	NEUTRAL	N
YELLOW/GREEN	EARTH	

THE EARTH HAS TO BE CONNECTED!

LIGHTING EFFECTS MUST NOT BE CONNECTED TO DIMMING-PACKS.

	<p>DANGER TO LIFE! BEFORE USING UNIT FOR THE FIRST TIME, THE INSTALLATION HAS TO BE APPROVED BY AN EXPERT!</p>
---	---

OPERATION

INITIALIZATION

AFTER YOU CONNECT THE EFFECT TO THE MAINS, THE KAM LED-800S INTELLIGENT LED COLOUR SYSTEM STARTS RUNNING. THE LCD ILLUMINATE

AFTER INITIALIZATION, THE LCD WILL DISPLAY “ADDR ***” WHEN THERE IS DMX CONNECTION. (** INDICATES THE PRESENT DMX ADDRESS.) BUT WHEN THERE IS NO DMX CONNECTION, INSTEAD, IT WILL DISPLAY THE PRESET NON-DMX RUNNING MODE: AUTO, SOUND, OR MANUAL.

LCD MENU SEQUENCE

ROLL THE WHEEL BY THE LCD CLOCKWISE, IT WILL SHOW MENU OPTIONS IN THE FOLLOWING SEQUENCE:

*ADDR *** , MANUAL BLUE ***, MANUAL GREEN***, MANUAL RED ***, NO DMX
AUTO/SOUND/MANUAL, CHASE 8 S***F_**, CHASE 8 S***F **, CHASE 7 S***F_**, CHASE 7
S***F **, CHASE 6 S***F_**, CHASE 6 S***F **, CHASE 5 S***F_**, CHASE 5 S***F **, CHASE 4
S***F_**, CHASE 4 S***F **, CHASE 3 S***F_**, CHASE 3 S***F **, CHASE 2 S***F_**, CHASE 2
S***F **, CHASE 1 S***F_**, CHASE 1 S***F **, DMX MODE 3CHANNEL/6CHANNEL
B-GROUP/4-GROUP/2-GROUP/1-GROUP, DMX MODE 3CHANNEL/6CHANNEL*

THE ABOVE SEQUENCE IS LOOPING,. PRESS THE ROLLING WHEEL TO ENTER SETTINGS OF THE DESIRED MENU OPTION.

NOTE: WHENEVER IDLE FOR 3 SECONDS, THE LCD WILL DIM DOWN ITS BACKGROUND ILLUMINATION AND WILL DISPLAY “ADDR ***” WHEN THERE IS DMX CONNECTION. (** INDICATES THE PRESENT DMX

ADDRESS.) BUT WHEN THERE IS NO DMX CONNECTION, INSTEAD, IT WILL DISPLAY THE PRESET NON-DMX RUNNING MODE: AUTO, SOUND, OR MANUAL. WHEN YOU OPERATE IT AGAIN, THE LCD WILL RETURN TO THE LAST MENU OPTION BEFORE IDLING.

ADDRESSING

THE CONTROL BOARD ALLOWS YOU TO ASSIGN THE DMX FIXTURE ADDRESS, WHICH IS DEFINED AS THE FIRST CHANNEL FROM WHICH THE LED-800S INTELLIGENT LED COLOUR SYSTEM WILL RESPOND TO THE CONTROLLER.

FOR ADDRESS SETTING, PRESS THE ROLLING WHEEL AND TURN IT, CLOCK-WISE TO DECREASE VALUE, ANTI TO INCREASE. PRESS AGAIN TO CONFIRM.

NOTE: OVERLAPPED ADDRESS CODES FOR DIFFERENT FIXTURES ARE NOT SUGGESTED. EXCEPTION, SEE **COMBINATIONS OF GROUP MODE AND CHANNEL MODE.**

LED BRIGHTNESS ADJUSTMENT

THE CONTROL BOARD ALLOWS YOU TO ADJUST THE BRIGHTNESS OF THE LEDs. TO ADJUST, PRESS THE ROLLING WHEEL AND TURN IT, UNTIL THE DISPLAY SHOWS

*MANUAL BLUE **** (TO ADJUST THE BRIGHTNESS OF THE BLUE LEDs)

*MANUAL GREEN **** (TO ADJUST THE BRIGHTNESS OF THE GREEN LEDs)

*MANUAL RED **** (TO ADJUST THE BRIGHTNESS OF THE RED LEDs)

THE ADJUSTING VALUE RANGES FROM 0-255, THE HIGHER THE VALUE, THE BRIGHTER THE BLUE LEDs. TO ENTER THESE SETTINGS, PRESS THE WHEEL. CLOCK-WISE TO DECREASE THE VALUE, ANTI-CLOCKWISE TO INCREASE. PRESS AGAIN TO CONFIRM.

NON DMX RUNNING MODES

TO SET NON DMX RUNNING MODES, DISCONNECT THE FIXTURES FROM THE DMX CONTROLLER, AND THEN PRESS THE ROLLING WHEEL AND TURN IT, UNTIL THE DISPLAY SHOWS

NO DMX AUTO/SOUND/MANUAL

TO ENTER THIS SETTING, PRESS THE WHEEL. AUTO/SOUND/MANUAL ARE IN SEQUENCE. *AUTO* INDICATES THE AUTO RUNNING MODE; *SOUND*, THE SOUND ACTIVATION MODE; AND *MANUAL*, THE MANUAL OPERATION MODE. PRESS THE WHEEL AGAIN TO CONFIRM WHEN THE DESIRED RUNNING MODE IS SELECTED.

CHASE

A CHASE IS A SEQUENCE OF DIFFERENT STEPS THAT WILL BE CALLED UP ONE AFTER ANOTHER IN A CONTINUOUS LOOP. WITH LED-800 INTELLIGENT LED COLOUR SYSTEM, YOU CAN SELECT UP TO 8 DIFFERENT CHASERS WITH SPEED AND FADE TIME ADJUSTABLE.

FOR EXAMPLE, TO SET FADE TIME OF CHASE 8, PRESS THE ROLLING WHEEL AND TURN IT, TILL SHOWS:

*CHASE 8 S***F_***

PAY ATTENTION TO POSITION OF THE CURSOR. WHEN THE CURSOR IS FLASHING RIGHT AFTER THE LETTER "F", AS SHOWN ABOVE, PRESS THE WHEEL, THEN YOU CAN ADJUST THE FADE TIME OF CHASE 8. PRESS AGAIN TO CONFIRM.

TO SET RUNNING SPEED OF CHASE 8, PRESS THE ROLLING WHEEL AND TURN IT, UNTIL THE DISPLAY SHOWS

*CHASE 8 S_***F ***

ALSO PAY ATTENTION TO POSITION OF THE CURSOR. WHEN THE CURSOR IS FLASHING RIGHT AFTER THE LETTER "S", AS SHOWN ABOVE, PRESS THE WHEEL, THEN YOU CAN ADJUST THE RUNNING SPEED OF CHASE 8. PRESS AGAIN TO CONFIRM.

NOTE: BEFORE PRESSING THE WHEEL, YOU CAN SWITCH BETWEEN THE OPTIONS "S" AND "F" BY ROLLING THE WHEEL BACK OR FORTH. CHASE 1 TO CHASE 7 IS WITH THE SAME OPERATION AS DESCRIBED IN CHASE 8.

DMX MODE: GROUP

THE LEDs ON THE FRONT PANEL ARE EVENLY DIVIDED IN 8 SQUARE BLOCKS, WHICH CAN BE GROUPED WITH DIFFERENT NUMBERS OF BLOCKS. TO SET THE GROUP, PRESS THE WHEEL AND ROLL IT UNTIL

THE DISPLAY SHOWS

DMX MODE 8-GROUP/4-GROUP/2-GROUP/1-GROUP

8/4/2/1 HERE INDICATES THE NUMBERS OF LED BLOCK(S). FOR EXAMPLE, 1-GROUP MEANS EACH SINGLE LED BLOCK IS A GROUP. 2-GROUP MEANS 2 LED BLOCKS ARE IN 1 GROUP. 4-GROUP, 4 IN 1; 8-GROUP, ALL 8 LED BLOCKS ARE IN 1 GROUP. ONCE THE DESIRED OPTION SELECTED, PRESS THE WHEEL AGAIN TO CONFIRM.

DMX MODE: CHANNEL

EACH LED GROUP HAS 3-CHANNEL MODE AND 6-CHANNEL MODE. TO SET THE CHANNEL MODE, PRESS THE WHEEL AND ROLL IT UNTIL THE DISPLAY SHOWS

DMX MODE 3CHANNEL/6CHANNEL

TO SET THE CHANNEL MODE, PRESS THE WHEEL AND ROLL IT. CLOCKWISE FOR 6-CHANNEL MODE; ANTI FOR 3-CHANNEL MODE; PRESS THE WHEEL AGAIN TO CONFIRM.

DMX PROTOCOL OF 3-CHANNEL MODE:

CHANNEL 1 - RED

DECIMAL		PERCENTAGE		FEATURE
0	255	0%	100%	RED LEDS FROM OFF TO FULL ON.

CHANNEL 2 - GREEN

DECIMAL		PERCENTAGE		FEATURE
0	255	0%	100%	GREEN LEDS FROM OFF TO FULL ON.

CHANNEL 3 - BLUE

DECIMAL		PERCENTAGE		FEATURE
0	255	0%	100%	BLUE LEDS FROM OFF TO FULL ON.

DMX PROTOCOL OF 6-CHANNEL MODE:

CHANNEL 1 - FANTASTIC EFFECTS

DECIMAL		PERCENTAGE		FEATURE
0	4	0%	2%	NO FUNCTION
5	5	2%	2%	FULL ON
6	247	2%	97%	FANTASTIC EFFECTS. (LEDS CHANGE EACH TWO DMX VALUES.)
248	255	97%	100%	FULL ON

CHANNEL 2 - RED

DECIMAL		PERCENTAGE		FEATURE
0	255	0%	100%	RED LEDS FROM OFF TO FULL ON.

CHANNEL 3 - GREEN

DECIMAL		PERCENTAGE		FEATURE
0	255	0%	100%	GREEN LEDS FROM OFF TO FULL ON.

CHANNEL 4 - BLUE

DECIMAL		PERCENTAGE		FEATURE
0	255	0%	100%	BLUE LEDS FROM OFF TO FULL ON.

CHANNEL 5 - STROBE

DECIMAL		PERCENTAGE		FEATURE
1	4	0%	2%	NO FUNCTION
5	253	2%	99%	STROBE, SLOW TO FAST
254	255	100%	100%	FULL ON

CHANNEL 6 - BUILT-IN PROGRAMS

DECIMAL		PERCENTAGE		FEATURE
0	4	0%	2%	NO FUNCTION
5	30	2%	12%	BUILT-IN PROGRAM 1
31	60	12%	24%	BUILT-IN PROGRAM 2
61	90	24%	35%	BUILT-IN PROGRAM 3
91	120	36%	47%	BUILT-IN PROGRAM 4
121	150	47%	59%	BUILT-IN PROGRAM 5
151	180	59%	71%	BUILT-IN PROGRAM 6
181	210	71%	82%	BUILT-IN PROGRAM 7
211	240	83%	94%	BUILT-IN PROGRAM 8
241	255	95%	100%	SOUND ACTIVATION MODE

COMBINATIONS OF GROUP MODE AND CHANNEL MODE

WHEN THE LED-800S IS SET AS IN 8-GROUP AND 3CHANNEL, IT MEANS ALL 8 LED BLOCKS OF THE LED-800 ARE IN ONE GROUP AND THE GROUP HAS GOT ONLY 3 CHANNELS.

CH 1-3	CH 1-3	CH 1-3	CH 1-3
CH 1-3	CH 1-3	CH 1-3	CH 1-3

4-GROUP, 3CHANNEL: AS 4 LED BLOCKS ARE IN ONE GROUP, SO THE 8 LED BLOCKS ARE DIVIDED INTO 2 GROUPS; EACH GROUP HAS GOT 3 CHANNELS, WHICH MAKES THE FIXTURE WITH TOTAL 6 CHANNELS.

CH 4-6	CH 4-6	CH 4-6	CH 4-6
CH 1-3	CH 1-3	CH 1-3	CH 1-3

2-GROUP, 3CHANNEL: AS 2 LED BLOCKS ARE IN ONE GROUP, SO THE 8 LED BLOCKS ARE DIVIDED INTO 4 GROUPS; EACH GROUP HAS GOT 3 CHANNELS, WHICH MAKES THE FIXTURE WITH TOTAL 12 CHANNELS.

CH 10-12	CH 10-12	CH 7-9	CH 7-9
CH 4-6	CH 4-6	CH 1-3	CH 1-3

1-GROUP, 3CHANNEL: AS 1 LED BLOCK IS IN ONE GROUP, SO THE 8 LED BLOCKS ARE DIVIDED INTO 8 GROUPS; EACH GROUP HAS GOT 3 CHANNELS, WHICH MAKES THE FIXTURE WITH TOTAL 24 CHANNELS.

CH 22-24	CH 19-21	CH 16-18	CH 13-15
CH 10-12	CH 7-9	CH 4-6	CH 1-3

8-GROUP AND 6CHANNEL: ALL 8 LED BLOCKS ARE IN ONE GROUP AND THE GROUP HAS GOT 6 CHANNELS.

CH 1-6	CH 1-6	CH 1-6	CH 1-6
CH	CH	CH	CH

1-6	1-6	1-6	1-6
-----	-----	-----	-----

4-GROUP, 6CHANNEL: AS 4 LED BLOCKS ARE IN ONE GROUP, SO THE 8 LED BLOCKS ARE DIVIDED INTO 2 GROUPS; EACH GROUP HAS GOT 6 CHANNELS, WHICH MAKES THE FIXTURE WITH TOTAL 12 CHANNELS.

CH 7-12	CH 7-12	CH 7-12	CH 7-12
CH 1-6	CH 1-6	CH 1-6	CH 1-6

2-GROUP, 6CHANNEL: AS 2 LED BLOCKS ARE IN ONE GROUP, SO THE 8 LED BLOCKS ARE DIVIDED INTO 4 GROUPS; EACH GROUP HAS GOT 6 CHANNELS, WHICH MAKES THE FIXTURE WITH TOTAL 24 CHANNELS.

CH 19-24	CH 19-24	CH 13-18	CH 13-18
CH 7-12	CH 7-12	CH 1-6	CH 1-6

1-GROUP, 6CHANNEL: AS 1 LED BLOCK IS IN ONE GROUP, SO THE 8 LED BLOCKS ARE DIVIDED INTO 8 GROUPS; EACH GROUP HAS GOT 6 CHANNELS, WHICH MAKES THE FIXTURE WITH TOTAL 48 CHANNELS.

CH 43-48	CH 37-42	CH 31-36	CH 25-30
CH 19-24	CH 13-18	CH 7-12	CH 1-6

CHANNELS OF EACH GROUP WILL RUN ACCORDINGLY TO ITS PRESET CHANNEL MODE (3-CHANNEL MODE OR 6-CHANNEL MODE).

IF TWO OR MORE LED-800S'S ARE SET AS IN THE SAME COMBINATION OF GROUP MODE AND CHANNEL MODE, THE DMX ADDRESS CODES OF THESE LED-800S'S CAN ALSO BE SET AS THE SAME CODE. OF COURSE, THEY WILL RUN THE SAME AS WELL. EXCEPT FOR THIS CASE, HOWEVER, OVERLAPPED DMX ADDRESS CODES ARE NOT SUGGESTED.

MASTER-SLAVE RUNNING MODE

WHEN TWO OR MORE LED-800S'S ARE CONNECTED TOGETHER, DISCONNECT THE DMX SIGNAL, AND SET ONE OR MORE LED-800S'S TO SOUND ACTIVATION MODE (SEE **NO DMX AUTO/SOUND/MANUAL**), THE LED-800S'S ARE THEN IN MASTER-SLAVE RUNNING MODE.

NOTE: THE MASTER WILL BE RANDOMLY SELECTED AS ONE OF THE SOUND ACTIVATED FIXTURES, AND IT IS NOT FIXED, IT CAN CHANGE TO ANOTHER SOUND ACTIVATED FIXTURE AT ANY TIME.

CLEANING AND MAINTENANCE



DANGER TO LIFE!
DISCONNECT FROM MAINS BEFORE ANY MAINTENANCE OPERATION!

WE RECOMMEND A FREQUENT CLEANING OF THE DEVICE. PLEASE USE A SOFT LINT-FREE AND MOISTENED CLOTH. NEVER USE ALCOHOL OR SOLVENTS!

THERE ARE NO SERVICEABLE PARTS INSIDE THE DEVICE EXCEPT FOR THE FUSE. MAINTENANCE AND SERVICE OPERATIONS ARE ONLY TO BE CARRIED OUT BY AUTHORIZED DEALERS.

REPLACING THE FUSE

IF THE FUSE OF THE DEVICE BLOWS, ONLY REPLACE THE FUSE WITH A FUSE OF SAME TYPE AND

RATING.

BEFORE REPLACING THE FUSE, UNPLUG MAINS LEAD.

PROCEDURE:

STEP 1: TAKE OUT THE FUSE HOLDER UNDER THE POWER SUPPLY.

STEP 2: REMOVE THE OLD FUSE FROM THE FUSE HOLDER.

STEP 3: INSTALL THE NEW FUSE IN THE FUSE HOLDER.

STEP 4: REPLACE THE FUSE HOLDER IN THE HOUSING

SHOULD YOU NEED ANY SPARE PARTS, PLEASE USE GENUINE PARTS.

IF THE POWER SUPPLY CABLE OF THIS DEVICE BECOMES DAMAGED, IT HAS TO BE REPLACED BY AUTHORIZED DEALERS ONLY IN ORDER TO AVOID HAZARDS.

SHOULD YOU HAVE FURTHER QUESTIONS, PLEASE CONTACT YOUR DEALER.

TECHNICAL SPECIFICATIONS

POWER SUPPLY	90V-250V AC, 47-64 Hz
POWER CONSUMPTION	55W
SOUND-CONTROL	VIA BUILT-IN MICROPHONE
PACKING SIZE (LxWxD)	820 X 117 X 73 MM
NET WEIGHT	4.9KG
GROSS WEIGHT	5.3 KG
MAXIMUM AMBIENT TEMPERATURE T _A	45
MAXIMUM HOUSING TEMPERATURE T _B (STEADY STATE)	60
FUSE	F2A, 250 V



www.kam.co.uk

Due to constant product development all specifications are subject to alteration without notice.