

## TH-15A

The Mackie TH-15A is a full-range, portable, powered loudspeaker system providing high-output, ultra-wide dispersion and low-distortion performance in a compact, lightweight design. Two Fast Recovery™ amplifiers independently power a 15-inch neodymium woofer and a precision 1-inch compression driver. Mackie's sophisticated Active electronics provide phase correction, crossover, time correction, equalization and protection circuitry.

Mackie-designed Active electronics provide a host of processing designed to enhance the performance of the TH-15A. Equalization, crossover, and time alignment are working at all times to improve sonic performance. Protective circuitry includes over-excursion protection, thermal protection shutdown, auto reset, and driver protection, including independent HF and LF compressors.

The TH-15A features a number of dedicated controls including an EQ on/off switch, a 3-band EQ/contour section, and a single microphone and line input level control.

The center of gravity, handle locations, handle design, and ease of use have been ergonomically designed. There is also an integrated pole mount cup and a weather-resistant steel grille. The trapezoidal cabinet has been designed to provide an ideal floor monitoring position.

The cabinet is constructed of high-pressure injected polypropylene. The enclosure features reinforcement ribbing and structural strengthening resulting in a strong, super-rigid design providing ideal acoustical characteristics.

## APPLICATIONS

Small club/band PA systems, houses of worship, DJs, vocal/band monitor wedges, gymnasiums, banquet halls, conference rooms and many, many more.



## FEATURES:

- 2-way bi-amplified, optimized powered loudspeaker system
- 400W peak of ultra-efficient Fast Recovery™ amplification
  - LF 300W peak power (Class-D)
  - HF 100W peak power (Class-A/B)
- High-output transducers
  - 15" high-precision woofer
  - 1" compression driver
- Mackie Active electronics provide total system optimization
  - Precision 2-way crossover
  - Transducer time-alignment
- User-adjustable 3-band contour EQ with sweepable mid-frequency
- Mic/Line input for direct connection of a microphone or mixer output
- Tough, impact-resistant polypropylene enclosure
- Pole-mountable and floor wedge-able
- Extremely lightweight and portable (36 lb / 16.3 kg)

## TH-15A SPECIFICATIONS

### Acoustic Performance

Frequency Response (-10 dB)	40 Hz - 20 kHz
Frequency Response (-3 dB)	50 Hz - 18.5 kHz
Horizontal Coverage Angle	90°
Vertical Coverage Angle	60°
Max SPL long-term	113 dB @ 1 m
Max SPL peak	116 dB @ 1 m

### Input / Output

Input Type	Female XLR Balanced/Unbalanced
Input Impedance	20 k $\Omega$ balanced bridging; 10 k $\Omega$ unbalanced
Loop-through	Male XLR Balanced/Unbalanced (parallel with input)
Level Control	Rotating knob 0 dB at center
Sensitivity	+4 dBu for full output (Level Control @ Center) -36 dBu for full output (Level Control @ Max)

### Transducers

Low Frequency	15 in / 381 mm with steel frame, paper cone woofer
High Frequency	Horn-loaded 1 in / 25 mm exit compression driver

### Power Amplifiers

Low Frequency Power Amplifier	
Rated Power	150 watts, 8 $\Omega$ load 300 watts peak
Signal-to-Noise Ratio	-94 dB, 20 Hz to 20 kHz, unweighted, referenced to 138 watts into 8 $\Omega$
Design	BTL Class D
High Frequency Power Amplifier	
Rated Power	50 watts, 4 $\Omega$ load 100 watts peak
Signal-to-Noise Ratio	-97 dB, 20 Hz to 20 kHz, unweighted, referenced to 50 watts into 4 $\Omega$
Design	Class AB

### Electronic Crossover

Crossover Type	24 dB / octave
Crossover Frequency	3 kHz

### Equalization

Low	$\pm$ 15 dB @ 80 Hz
Mid	$\pm$ 15 dB sweep 100 Hz-8 kHz
High	$\pm$ 15 dB @ 12 kHz
Direct/EQ Switch	Bypasses EQ section

### Protection Features

Over-excursion Protection	Second-order sub-sonic filter
Thermal Protection	Independent amplifier shutdown, auto reset
Driver Protection	Independent HF and LF compressors

### AC Power Requirements

US	100 - 120 VAC, 50 - 60 Hz 320 watts
EU, CN	200 - 240 VAC, 50 - 60 Hz 320 watts
AC Connector	3-pin IEC 250 VAC, 20 A male

### Construction Features

Basic Design	Trapezoidal
Material	Polypropylene
Finish	Textured
Handles	One on each side, one on top
Grille	Perforated metal with weather-resistant coating
Display LEDs	
Front	Power ON
Rear	Power ON, OL (overload)
Operating Temperature	0° - 40°C 32° - 104°F

### Physical Properties (packaged product)

Height	29.0 in / 737 mm
Width	17.5 in / 445 mm
Depth	17.0 in / 432 mm
Shipping Weight	39.0 lb / 17.7 kg

### Physical Properties (product)

Height	27.6 in / 702 mm
Width	16.8 in / 427 mm
Depth	15.5 in / 394 mm
Weight	36.0 lb / 16.3 kg

### Mounting Methods

Pole-mountable via the built-in socket on the bottom of the cabinet. Be sure the pole is capable of supporting the weight of the TH-15A.

### Options

SPM200 Loudspeaker Pole Mount	P/N 2035170-01
-------------------------------	----------------

### Ordering Information

TH-15A 15" 2-way Compact SR Loudspeaker, US	P/N 2034164-00
TH-15A 15" 2-way Compact SR Loudspeaker, EU	P/N 2034164-01
TH-15A 15" 2-way Compact SR Loudspeaker, CN	P/N 2034164-05

## TH-15A HORIZONTAL POLARS

Gridlines: 6 dB axial / 15 degrees radial

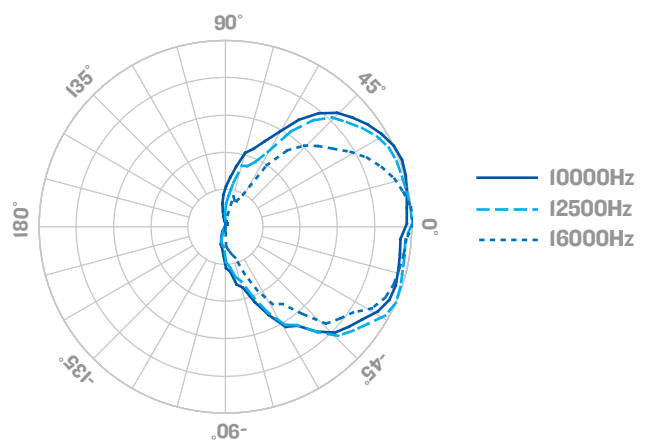
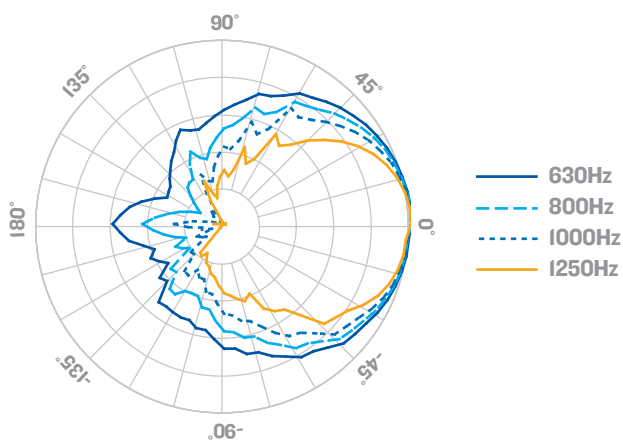
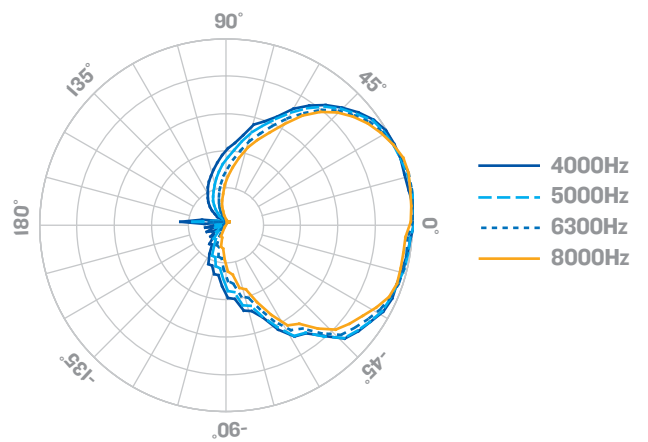
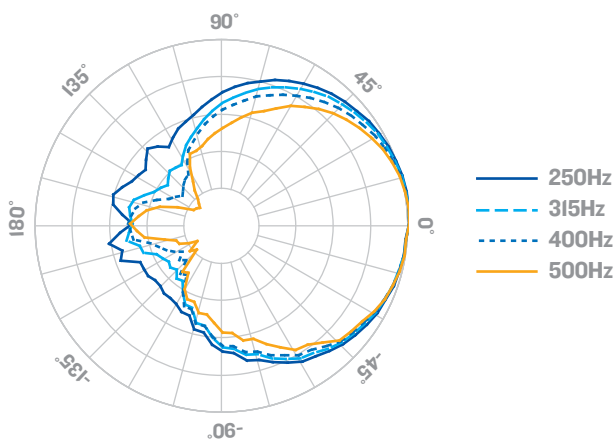
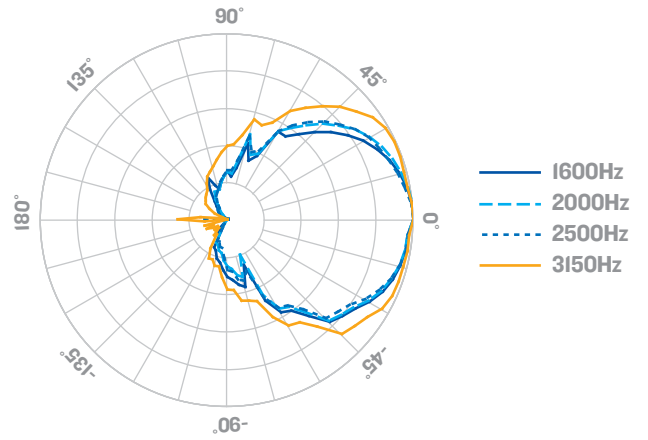
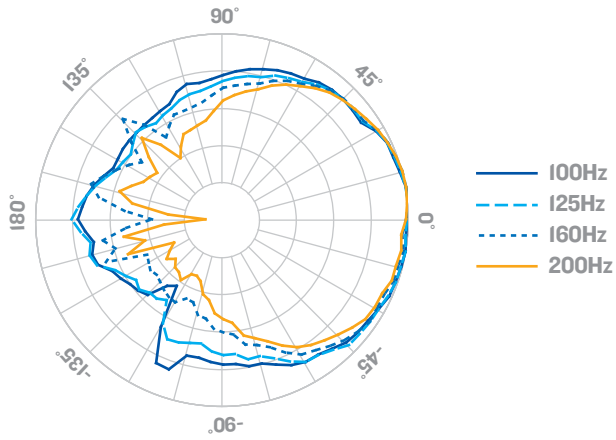

## TH-15A VERTICAL POLARS

Gridlines: 6 dB axial / 15 degrees radial

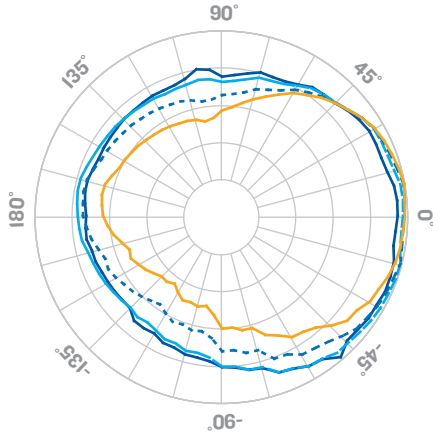

— 100Hz  
- - 125Hz  
... 160Hz  
— 200Hz

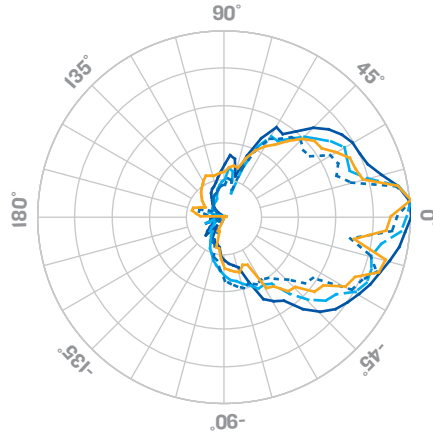

— 1600Hz  
- - 2000Hz  
... 2500Hz  
— 3150Hz

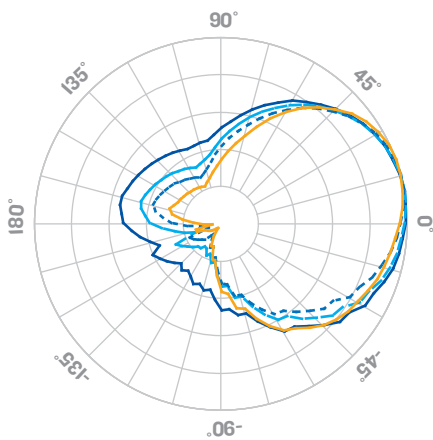

— 250Hz  
- - 315Hz  
... 400Hz  
— 500Hz

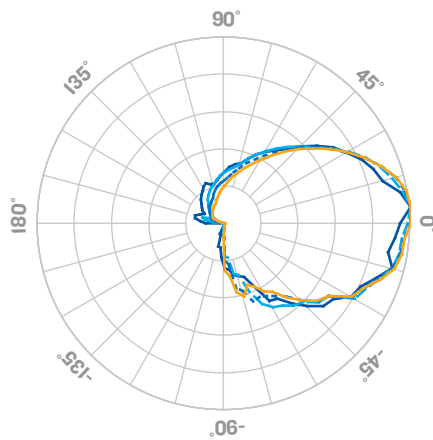

— 4000Hz  
- - 5000Hz  
... 6300Hz  
— 8000Hz

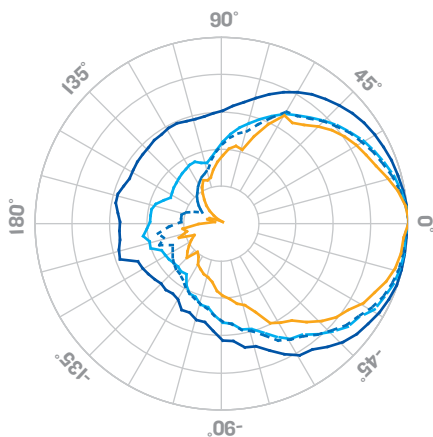

— 630Hz  
- - 800Hz  
... 1000Hz  
— 1250Hz

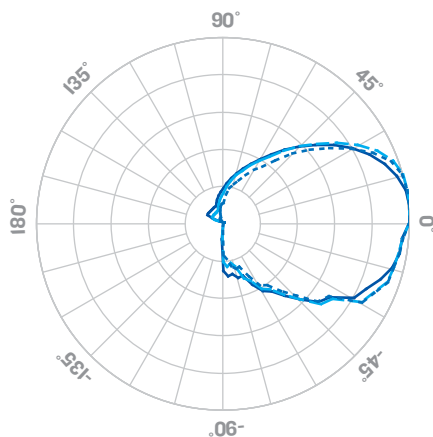

— 10000Hz  
- - 12500Hz  
... 16000Hz

## TH-15A FREQUENCY RESPONSE

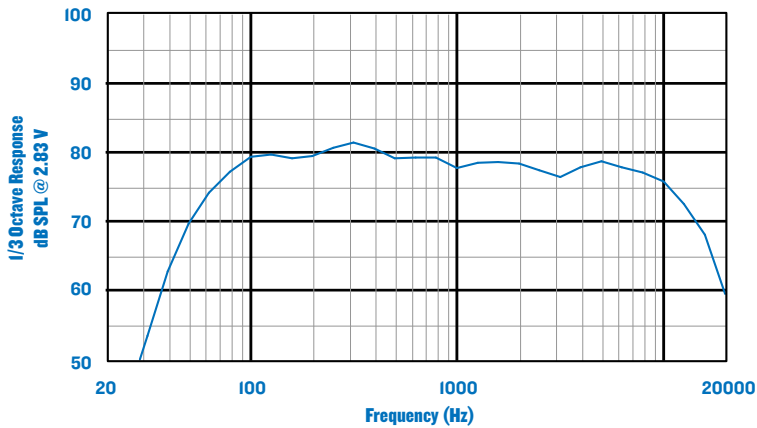

## TH-15A INPUT PANEL

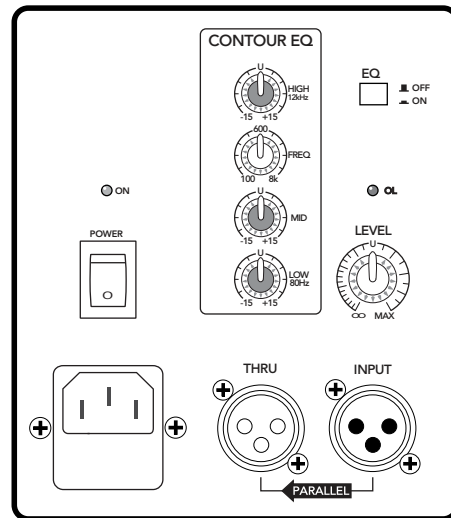

## TH-15A DIMENSIONS

### NOTES:

1. WEIGHT APPROX. 36.0 lb [16.3 kg].
2. SHIPPING WEIGHT APPROX. 39.0 lb [17.7 kg].

UNLESS OTHERWISE SPECIFIED: ALL DIMENSIONS ARE IN INCHES. DUAL [MM] DIMENSIONS FOR REF ONLY

TOLERANCES  
 LINEAR  $\pm 0.13$  in./  $\pm 3.3$ mm; ANGLES  $\pm 1^\circ$

(X.XX) = REF DIMS

NO TOLERANCE IMPLIED

TSC=THEORETICAL SHARP CORNER

DIMENSIONS ACROSS CENTERLINES  
 TO BE SYMMETRICAL

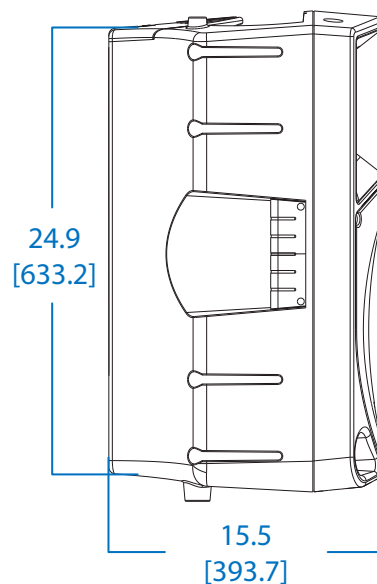
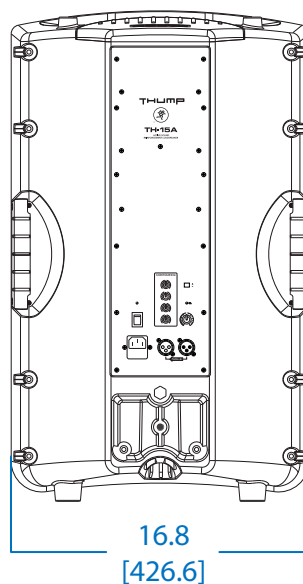
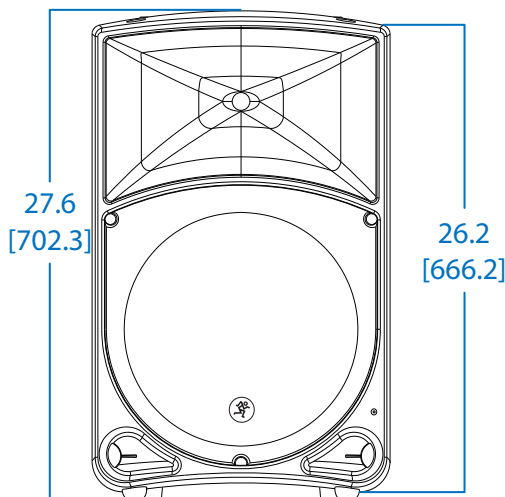
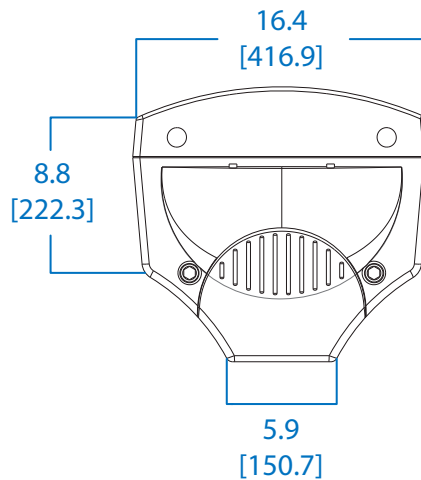

## TH-15A BLOCK DIAGRAM

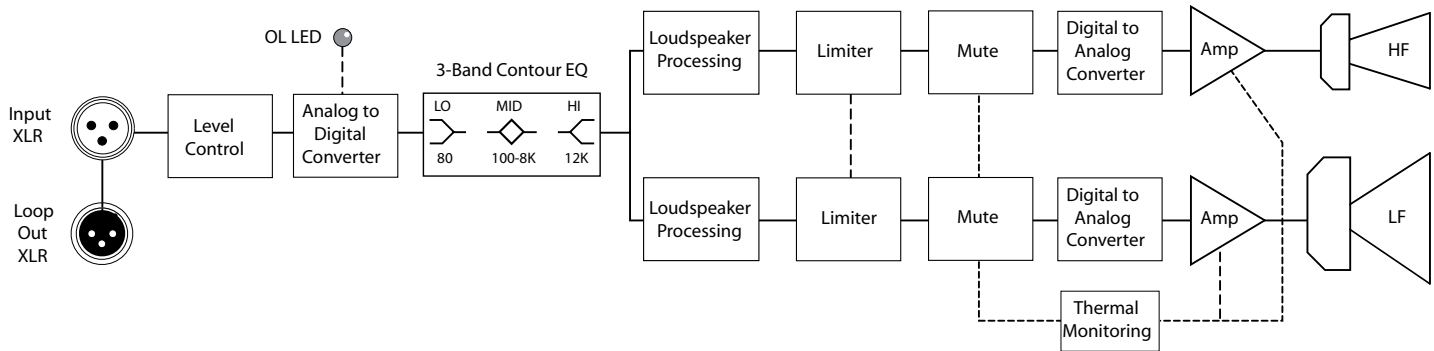

Electronic files for this product are available at:

[www.mackie.com](http://www.mackie.com)

Specification Sheet

TH-15A\_SS.PDF

Owner's Manual

TH-15A\_OM.PDF

# MACKIE®

www.mackie.com

16220 Wood-Red Road NE

Woodinville, WA 98072 USA

800-898-3211, Fax 425-487-4337, sales@mackie.com

Part No. SW0860 Rev. B 09/10

Since we are always striving to make our products better by incorporating new and improved materials, components, and manufacturing methods, we reserve the right to change these specifications at any time without notice. "Mackie" and the "Running Man" figure are registered trademarks of LOUD Technologies Inc. All other brand names mentioned are trademarks or registered trademarks of their respective holders, and are hereby acknowledged.

©2010 LOUD Technologies Inc. All Rights Reserved.