

AMERICAN AUDIO



POCKET RECORD

User Instructions

AMERICAN AUDIO
6122 S. Eastern Ave
Los Angeles Ca. 90040
www.americanaudio.us

POCKET RECORD	CONTENTS
----------------------	-----------------

WARRANTY REGISTRATION.....	2
UNPACKING.....	2
INTRODUCTION.....	3
FEATURES.....	3
NOTICE.....	4
 CONTROLS AND FUNCTIONS	
INPUTS, CONTROLS, AND FUNCTIONS.....	5
BUTTONS.....	5
MODE BUTTON CONTROL.....	6
BATTERY INSTALL/POWER ON AND OFF.....	7
MENU SET UP.....	7
 RECORDING	
MICROPHONES.....	9
ELECTRIC GUITAR AND LINE IN.....	9
RECORDING DISTANCE.....	10
PLAYBACK.....	11
DELETING FILES.....	12
TRANSFERRING FILES.....	12
SPECIFICATIONS.....	13

POCKET RECORD	WARRANTY REGISTRATION
----------------------	------------------------------

The Pocket Record carries a one year limited warranty. Please fill out the enclosed warranty card to validate your purchase. All returned service items whether under warranty or not, must be freight prepaid and accompany a return authorization (R.A.) number. The R.A. number must be clearly written on the outside of the return package. A brief description of the problem as well as the R.A. number must also be written down on a piece of paper and included in the shipping container. If the unit is under warranty, you must provide a copy of your proof of purchase invoice. You may obtain a R.A. number by contacting customer support at (800) 322-6337.

POCKET RECORD	UNPACKING
----------------------	------------------

Every Pocket Record has been thoroughly tested and has been shipped in perfect operating condition. Carefully check the shipping carton for damage that may have occurred during shipping. If the carton appears to be damaged, carefully inspect your mixer for any damage and be sure all equipment necessary to operate the mixer has arrived intact. In case damage has been found or parts are missing, please contact our toll free customer support number for further instructions, please do not return the mixer to your dealer.

Please Note: Specifications and improvements in the design of this unit and this manual are subject to change without any prior written or published notice.

Congratulations and thank you for purchasing the American Audio® Pocket Record portable digital audio recorder. This recorder is equipped with leading edge digital recording technology, excellent sound quality and is easily operated. It is suitable for acoustic instruments, electric guitars, microphones, keyboards, MP3 players, interviews, education, band rehearsal, ecological records...and more. The Pocket Record comes with a one year limited warranty! Please read and understand this manual completely before attempting to operate your new mixer. This booklet contains important information concerning the proper and safe operation of your new mixer.

Customer Support:

American Audio® provides a toll free customer support line, to provide set up help and to answer any question should you encounter problems during your initial set up or operation. You may also visit us on the web at www.AmericanAudio.us for any comments or suggestions. Service Hours are Monday through Friday 8:00 a.m. to 4:30 p.m. Pacific Standard Time.

Voice: (800) 322-6337
Fax: (323) 582-2941
E-mail: support@AmericanAudio.us

Caution! There are no user serviceable parts inside this mixer. Do not attempt any repairs yourself, doing so will void your manufacturer's warranty. In the unlikely event your mixer may require service, please contact American Audio® customer support.

Do not discard the packing carton in the trash. Please recycle when ever possible.

- 9 Groups and 99 Recording Tracks

The Pocket Record provides 1-9 groups, numbered 1-9, and 99 recording tracks for each group, for either the internal flash memory or SD card. You may select any blank track number you prefer to record on before you record, or the Pocket Record will select a blank track for you automatically. Whenever a track is recorded, the track number will be fixed and you will not be able to change it even if the previous track is deleted or added. There is no limit in recording time for each individual recording track.

- Two Storage Folders

The Pocket Record provides two folders for storage files: in FOLDER 1, you can record music either from the built-in microphone, from an external microphone, from an electric guitar and from Line-in sources and play it back. In FOLDER 2, you can download MP3 music from your PC or MAC and play it. The two flexible operation folders allow flexibility to organize your music for both your recording and leisure time.

- Leading and Unique Sound Mixer Technology

The Pocket Record is equipped with built-in microphones, and two audio inputs. When you connect audio inputs to record, the sound will automatically be mixed with the built-in microphone with a balance level. Our leading and unique sound mixing technology is perfect for occasions with multiple instruments playing, combinations with background music or for the creation of any creative music made by you!

- Multiple Audio Inputs Selection

The Pocket Record is equipped with two Audio-in jacks for Left & Right channel recording. You can select to plug in external microphone, electric guitar, or Line-in as recording sources, by changing the switch position of the Audio-in selector. The multiple audio input selection adds more convenience to your recording experience!

Please read the following before you use the Pocket Record:

1. Please read this guide carefully before you use the device.
2. Please notice the position to put batteries inside the Pocket Record
3. Please use the DC power adaptor of USB type in correct 5V DC specification.
4. Please do not take apart or repair the Pocket Record by yourself. Please bring the Pocket Record back to your retailer or to a local service vendor for repair and assistance.
5. In order to keep stable data transmission, please do not twist the USB cable when you plug it into the computer.
6. The built-in LCD display is a fragile electronic part, please do not press on it heavily and do not touch it with sharp objects. We suggest you use only special cloth to clean the LCD display. Please make sure that the LCD display does not get exposed to water.
7. The SD card is a very precise electronic device, please use it according to the following notice: Please do not remove the SD card from the recorder during data transmission. Do not bend, strike, drop or take apart the SD card. Do not put the SD card in a place with high temperature, high humidity or dust. Do not expose the SD card to static electricity. In addition:
 - Please make sure the SD card you are using has been formatted (the format type of the Pocket Record is FAT32).
 - Please release the write protection switch of SD card before you record.
 - The Pocket Record processes large amounts of data during recording and playback, as result, we strongly suggest you to use high speed SD cards as extension memory only, to prevent noise, data lost or any transmission problem.

We do not guarantee the function, operation or life of any SD card that is used in the device. We do not also take any responsibility of indemnity for the damage of SD cards. Like any digitally stored data, data shall be backed up regularly. In no event, we will be liable to any indirect incidental, special or consequential damages to any person caused by, or for any lost profits, lost savings, loss of use, loss revenues or lost data arising from or relating to this device.

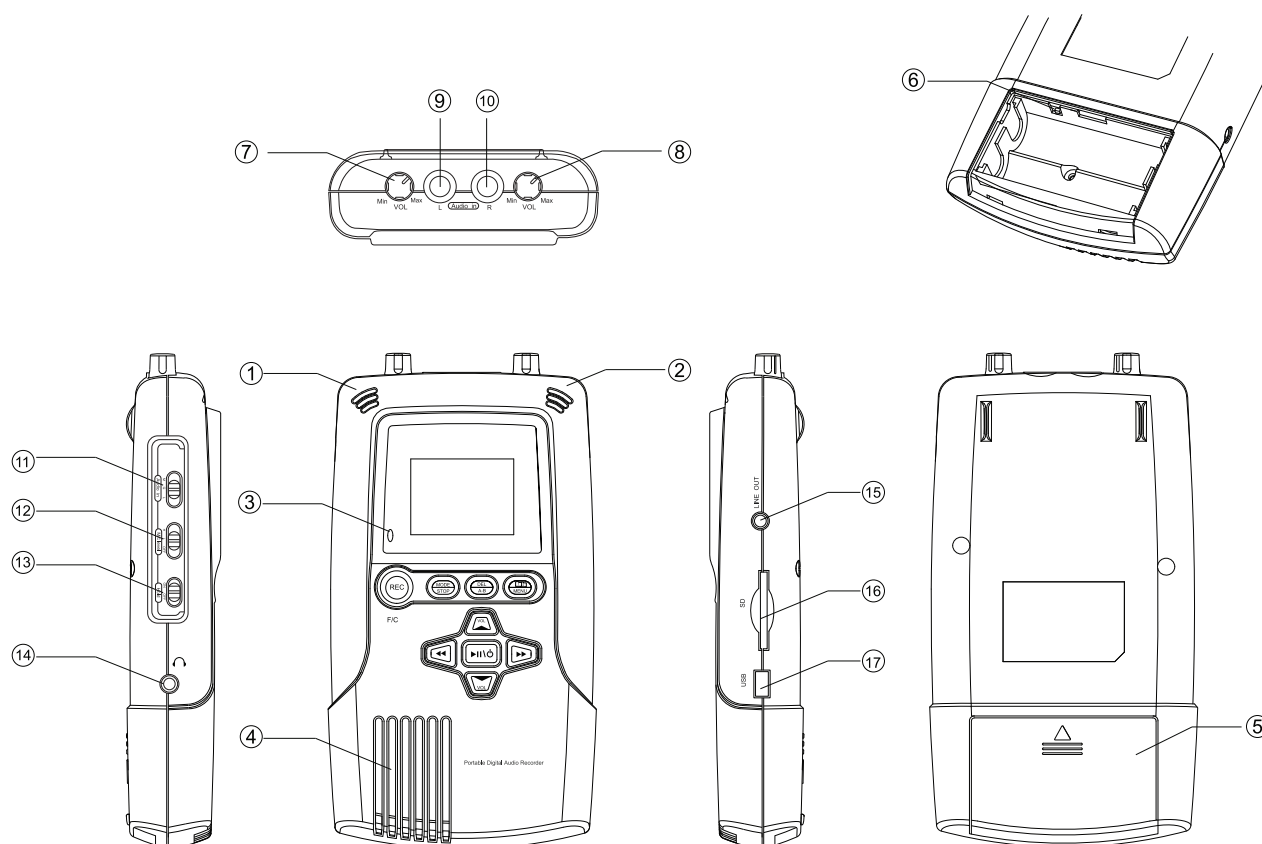

INPUTS, CONTROLS, & FUNCTIONS

1. BUILT-IN MICROPHONE “L” CHANNEL - A omni condenser microphone is installed into the device as the “L” (left) channel.

2. BUILT-IN MICROPHONE “R” CHANNEL - A omni condenser microphone is installed into the device as the “R” (right) channel.

3. RECORDING INDICATOR LED - This LED will glow during recording.

4. BUILT-IN SPEAKER - A monitor speaker is installed, this speaker will not function when earphones are plugged in.

5. BATTERY COVER - Open the cover and install two AA batteries into the battery compartment.

6. BATTERY SELECT SWITCH - When primary batteries (or Alkaline batteries) are installed, switch to “1.5V”. When Ni-MH rechargeable batteries are installed switch to “1.2V”.

7. VOLUME CONTROL KNOB FOR AUDIO-IN “L” CHANNEL.

8. VOLUME CONTROL KNOB FOR AUDIO-IN “R” CHANNEL.

9. AUDIO-IN “L” CHANNEL - This allows audio input of Microphone (M), Guitar (G) or Line In (L). It provides 1.5V power supply.

10. AUDIO-IN “R” CHANNEL - This allows audio inputs of Microphone (M), Guitar (G) or Line In (L). It provides 1.5V power supply.

11. AUDIO-IN SELECTOR - Use this selector switch to select one of three types of audio input types, Microphone (M), Guitar (G) or Line In (L).

- 12. BUILT-IN MICROPHONE SENSITIVITY SELECTOR** - Select the sensitivity level of the built-in microphones, High (H) or Low (L), or switch off the built-in microphone (OFF).
- 13. KEY HOLD SWITCH ON / OFF** - Put the switch to the “ON” position to put the key control on hold (stop running), or put the switch in the “OFF” position to release the key control.
- 14. EARPHONE JACK (STEREO)** - When an earphone is connected to this jack, the built-in speaker will not function.
- 15. LINE OUT PORT** - Use this line out port to connect to amplifier.
- 16. SD CARD SLOT** - Load your SD card here.
- 17. USB SOCKET / DC POWER IN** - Use a USB cable to connect to a computer. You may also use an USB type DC adaptor (DC 5V) to connect to a power outlet (power adaptor is not included).

BUTTONS:



RECORD BUTTON - Press this button to start recording.



MODE/STOP BUTTON - Press this button to stop or cancel operations (recording, playback, delete...)



DEL/A-B LOOP BUTTON - Press this button during playback to indicate a loop starting point (A), then press the button again to indicate the loop end point (B). The music will then play from A to B again and again in a loop until you press the button again to stop.



MENU BUTTON - Press this button to enter the MENU, press the button again to leave the MENU.



POWER/PLAY BUTTON - Press the button for 2 seconds to switch the recorder ON and press the button for 2 seconds to switch it OFF. Press the button to start PLAYBACK; pressing the button during playback to pause playback, push it again to continue playback.



LEFT/PREVIOUS TRACK/REWIND BUTTON - Press this button once to select the previous track; hold down the button to change the track number quickly. Hold down the key during playback to rewind, release the button to stop rewinding and go back to normal playback.



RIGHT/NEXT TRACK/FAST FORWARD BUTTON - Press this button once to select the next track; hold down the button to change the track number quickly. Hold down the key during playback to fast forward, release the button to stop fast forward and go back to normal playback.



VOL. UP/ UP SELECTOR BUTTON - Press this button during playback to increase the volume level. Press this button to scroll up for item selection when in MENU mode.







VOL. DOWN/ DOWN SELECTOR BUTTON - Press this button while playing to decrease the volume level. Press the button to scroll down for item selection in MENU mode.

MODE BUTTON CONTROL:

The MODE button provides additional functions. To access a MODE function, press the MODE button (the LCD will show MODE) and then press the desired function button immediately to operate the MODE function. Here is a description of the mode functions:



MEMORY SELECTION - Use this function to select the internal flash memory or the SD card memory as your record target and playback source.

-  This function will delete your desired tracks
-  With this function you can select between Folder 1 or Folder 2
-  Group number: decrease the selection function
-  Group number: increase the selection function

1. Open the battery cover and install two new AA batteries into the Pocket Record.
2. The Pocket Record works on both primary batteries (and Alkaline batteries) and Ni-MH rechargeable batteries. To use primary batteries, put the battery selector switch to the "1.5V" position; to use Ni-MH rechargeable batteries, select the "1.2V" position of the battery selector switch.
3. Hold the POWER/PLAY button for two seconds, the device will switch ON and enter the operating mode. To switch OFF the recorder hold the POWER/PLAY button again for two seconds.
4. The recorder will switch OFF automatically after 5 minutes if there is no activity.
5. The low battery icon on the LCD will glow when the batteries are at low power level, you should change the batteries at this point.

MENU SETUP:

Press the MENU button, and the LCD will show all of the main items of the MENU setup. Press either the LEFT or RIGHT buttons to move to the previous or next main items. Press the UP SELECTOR or DOWN SELECTOR buttons to interchange to the secondary items. Press the MENU button again to leave MENU mode.

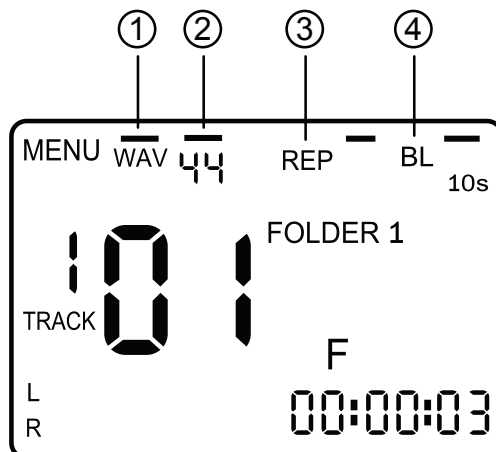

- 1. RECORDING FORMAT** - There are two formats available for recording, WAV and MP3.
- 2. SAMPLE RATE** - For WAV format, there are 6 sample rates to select: 8KHz, 11KHz, 16KHz, 22KHz, 32KHz, and 44KHz. For MP3 format, there is only one sample rate: 44KHz
- 3. REP(REPEAT)** - There are two repeat functions: REPEAT (the track will only be repeated) or REP All (the device will repeat all the tracks). The LCD will not show any icons if you do not select a REPEAT function.
- 4. BL(BACKLIGHT TIME)** - There are four backlight time for selections: ON (backlight always on); 10s (backlight turns off after 10 secs if there is no button activity); 20s (backlight turns off after 20 sec if there is no button activity); OFF (no backlight at all).

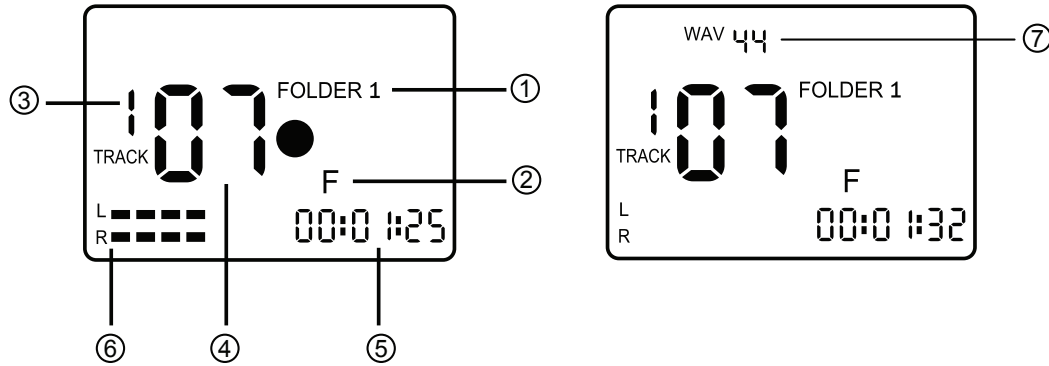
**RECORDING:**

1. You can ONLY record to FOLDER 1. To change to FOLDER 1 press the MODE/STOP button, and then the MENU button. The LCD will display FOLDER 1 (1), when you are in FOLDER 1.
2. The device allows you to record into the internal flash memory or into an installed SD card memory (2). The Pocket Record will change to the SD card memory automatically when an SD card is installed. To change between the internal flash memory “F” (2) and the SD card “C”, press the MODE/STOP button and then press the RECORD button.
NOTE: When recording to an SD card, please be advised that there might be a 2-3 second delay after you press the RECORD button.
3. Select a group number from 1 to 9 (3) to record to. To select your desired group number press the MODE/STOP button and then either the LEFT or RIGHT button to scroll to the number.
4. Press the LEFT or RIGHT buttons to select the track you want to record to. The track range is 1 - 99 (4). The track number you select to record to must be blank. Press the RECORD button to record. You can also just press the RECORD button directly, and the device will select a blank track that follows the last recorded track number (for example, if the last recorded track number is 05, the automatically selected track number will be 06).
5. When you press the RECORD button the Recording indicator LED will glow and “●” will be displayed in the LCD. The time clock will also start running (5). You can pause during recording by pressing the POWER/PLAY button. The recording indicator LED will start to flash indicating that you have paused the device. Press the POWER/PLAY button again to continue recording. When you are done recording press the MODE/STOP button.
6. During recording the volume indicator (6) will be shown on the LCD. The input volume can be adjusted by the Audio In Volume control (7 & 8). Do not set the volume to the highest level when recording, otherwise, the recording sound quality will be distorted.
7. When you finish recording, the recording format and sample rate (7) of the track will show up on the LCD.
8. For a longer recording time, put the KEY HOLD SWITCH (13) in the ON position. When you are done switch to the KEY HOLD SWITCH to the OFF position to release the key control.

RECORDING TO BUILT IN & EXTENSION MICROPHONES:

1. The Pocket Record is equipped with two built-in microphones. You can adjust sensitivity level of the built-in microphones using the built-in MICROPHONE SENSITIVITY SELECTOR (12). The high sensitivity level of the built-in microphone is -45dB (at 1KHz), while the low sensitivity level is -35dB (at 1KHz). You may also adjust the AUDIO IN VOLUME CONTROL (7 & 8) to make slight volume adjustment.
2. There are two Audio-in jacks for the Pocket Record a left and a right (9 & 10). They allow you to plug two extension microphones into the jacks for recording. If you use an extension microphone you must put the AUDIO IN SELECTOR switch (11) in the microphone "M" position. The two AUDIO-IN JACKS (9 & 10) both provide DC 1.5V power. You may use either the built in microphones or extension microphones as recording sources. When using extension microphones you may adjust the AUDIO IN VOLUME CONTROL knobs (7 & 8) for a proper recording sound level.
3. The recording source of the built-in microphones and the extension microphones will be mixed into two separate tracks (Left and Right channels) with a balanced level.
4. You can turn off the built-in microphones when recording using another source. Simply, switch the MICROPHONE SENSITIVITY SELECTOR (12) to the OFF positions.

RECORD FROM ELECTRIC GUITAR OR LINE IN:

1. The Pocket Record allows you to plug in an electric guitar as recording source. When using an electric guitar you must put the AUDIO IN SELECTOR switch (11) in the Guitar "G" position. When using an electric guitar you may adjust the AUDIO IN VOLUME CONTROL knobs (7 & 8) for a proper recording sound level.
2. The Pocket Record allows you to plug in a line-in source such as a CD player, tape deck, radio, etc as a recording source. When using a line in source you must put the AUDIO IN SELECTOR switch (11) in the Line In "L" position. When using a line in source you may adjust the AUDIO IN VOLUME CONTROL knobs (7 & 8) for a proper recording sound level.
3. The recording source of the built-in microphones and the electric guitar or line in recording source will be mixed into two separate tracks (Left and Right channels) with a balanced level.
4. You can turn off the built-in microphones when recording using another source. Simply, switch the MICROPHONE SENSITIVITY SELECTOR (12) to the OFF positions.

SUITABLE POSITION TO RECORD:

1. The Pocket Record's built-in microphone is a omni-directional condenser microphone. The diagram below shows the best sound recording area.

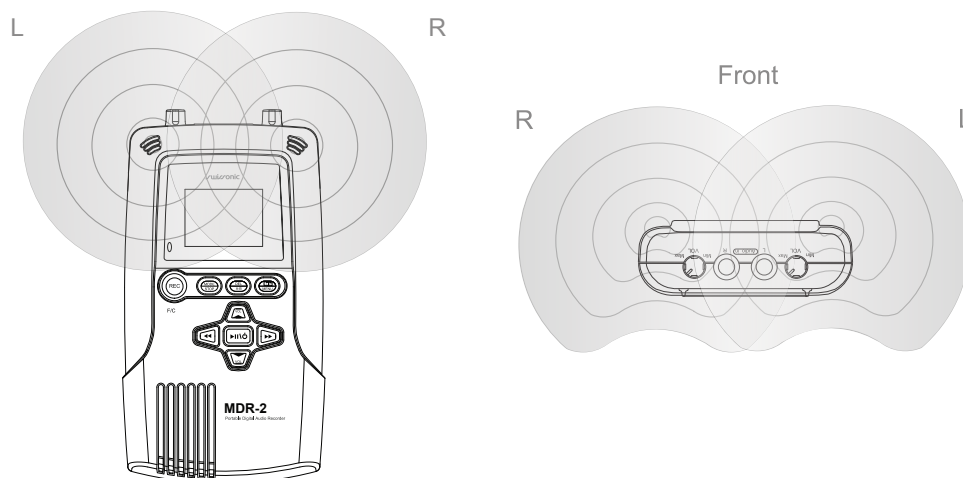

2. To get the best recording result, we suggest that you put the Pocket Record at a distance of around 60cm from the sound source, at about table height.
3. Adjust the input volume to a proper level. Do not set the volume to the highest level when recording, otherwise, the recording sound quality will be distorted.
4. In situations where multiple instruments are played simultaneously, the Pocket Record should be positioned closest to instruments with lowest sound levels – or you can use extension microphones for the different instruments.
5. If you want to record a speech (e.g. from a teacher) together with instruments playing, it is best, and we suggest the speaker uses the extensional lapel microphone to get the best results.
6. For a better recording quality, the extensional lapel microphone could also be clipped to a score stand or on the body of the speaker, depending on the situation.

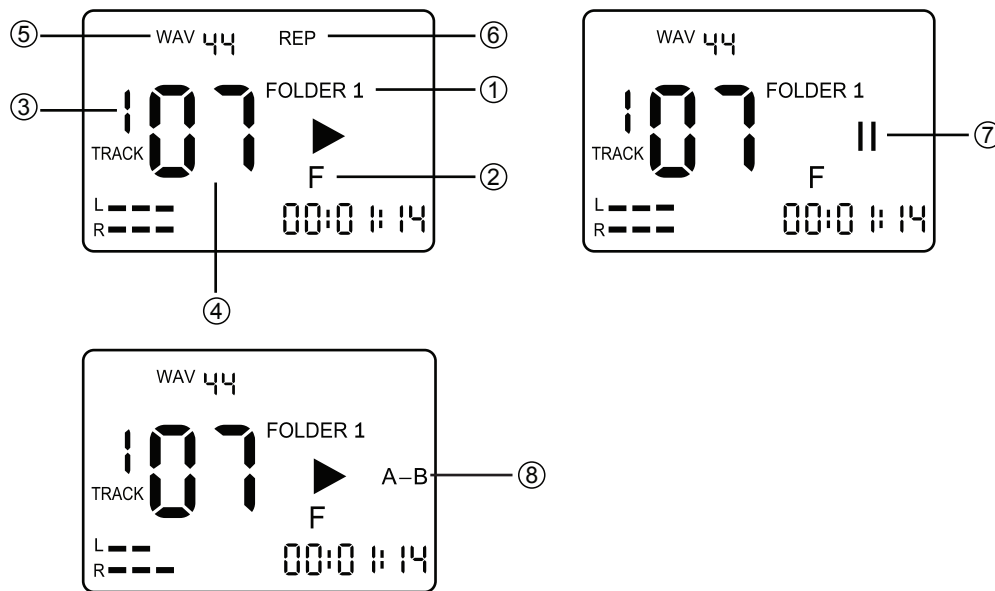

1. FOLDER 1 or FOLDER 2: FOLDER 1 stores and plays the files/tracks you have recorded with the Pocket Record. FOLDER 2 stores and plays the files downloaded/transferred from a computer. To change between the two folders, press the MODE/STOP button, and then the MENU button to interchange between FOLDER 1 and FOLDER 2 (1).

2. Playback from flash memory or SD card memory: Select the files you want to playback from the internal flash memory or SD card memory (2). Please see page 8 for further explanation.

3. Select the Group and track you want to playback: Press the MODE/STOP button and then either the RIGHT or LEFT buttons to select a group number between 1-9 (3). Then select the track to playback by pressing either the RIGHT or LEFT buttons to select a track between 1-99 (4). The recording format and sample rate of the track you select will show in the LCD display (5).

4. Playback: Press the POWER/PLAY button to start to playback, the play icon will be displayed in the LCD. You pause playback by pressing the POWER/PLAY button. The pause icon (7) will be displayed and flashing in the LCD. Press the POWER/PLAY button again to continue playback.

5. Forward and rewind during playback: Hold down the REWIND button during playback to rewind the playback. Hold down the FAST FORWARD button to forward the playback. Release either of the buttons to resume normal playback.

6. Repeat and Repeat All: Enter the MENU mode, and set up repeat mode. If you select REPEAT only the track will be repeated, if you select REP All the device will repeat all the tracks. The LCD will not show any icons if you do not select a REPEAT function. Please note that the REP All function will only work when your in FOLDER 2. The LCD will show your repeat mode in the LCD display (6).

7. A-B loop: Press the DEL/A-B button during playback to mark the starting point for a loop (A point), press the button again to mark the ending point for the loop (B point). The music will then play from A to B in a continuous loop until you press the DEL/A-B button again to stop the loop (8).

8. Volume adjustment: You can adjust the volume level of the earphone piece or built-in speaker by pressing either the VOLUME UP or VOLUME DOWN buttons during playback. The level adjustment range is 00-20.

DELETING TRACKS:

You can delete your recorded files via computer or using Pocket Record itself. To delete the your files using the Pocket Record, select the track you want to delete, press MODE/STOP button and then press DEL/A-B button, the LCD will show “dEL”. Press the DEL/A-B again, and the Pocket Record will start to delete the track. When the track has been deleted the LCD will show “DELETE” and the clock return to 00:00:00. This means the track is empty and you can now save a new recording.

The device can be connected to computer, to copy and store your recorded files onto your computer (to backup your data), or download/transfer music from your computer to the Pocket Record.

Connect one end of the USB cord to the port of the Pocket Record and the other end of cord to USB port on your computer.

Once connected to your computer, the computer will detect the Pocket Record as two removable disks/hard drives (the first disk/hard drive represents the built-in flash memory; the second disk/hard drive represents the SD card memory). In each disk/hard drive you will find folders for Groups 1–9.

The music you download from your computer to the Pocket Record will be stored in FOLDER 2, and the track number will depend on the sequence in which the files are transferred. This means that the track number in FOLDER 2 is not fixed and can be changed at any time if a track is deleted or added.

If you want the files to have a fixed track number, you can store the music in FOLDER 1. To do this, you simply need to change the file names. Follow the instructions below to store files in FOLDER 1.

a) If you want to download files to FOLDER 1, and store them in the built in flash memory, with a fixed track number, change the file name to M_INT_xx (xx is whatever track number you want it to be).

b) If you want to download files to FOLDER 1, and store them to a SD memory card, with a fixed track number, change the file name to M_EXT_xx (xx is whatever track number you want it to be).

The same way you connect to a wall outlet to power your Pocket Record you can power the Pocket Record off of a computer.

Once you have connected to the computer, press the MODE/STOP button once, the Pocket Record will now enter the operating mode, and now you can operated the Pocke Record with the power of the computer.

You can leave the operating mode by pressing the MODE/STOP button for 2 seconds.

Dimensions:	15.5(L) x 8.5(W) x 3(D) cm
Weight:	200g (not include batteries)
Recording media:	Internal flash memory 128MB, SD memory card (16MB - 2GB), SDHC memory card (4GB)
SD card format type:	FAT 32
Recording format:	WAV(16bit), sample rate:8/11/16/22/32/44.1KHz; MP3(128Kbps), sample rate: 44.1KHz.
Playback format:	WAV: PCM WAV with sampling rate of 8KHz, 16KHz, 32KHz and 44.1KHz, MP3: MPEG1,MPEG2,MPEG2.5Layer3,from 32K~320Kbps
S/N ratio at 1KHz:	55dB
Frequency response:	20 – 20KHz
Built-in microphone:	omni-directional condenser microphone type
Input:	Two 1/4” mono for selection of extension microphone, Line-in, and Electric Guitar (plug-in power 1.5V) Built-in stereo microphones(L & R).
Output:	1/8” stereo headphone 1/8”stereo Line out
Built-in speaker:	0.2Watt, 8 Ohm
USB interface:	Mini-B type (USB 2.0 Full-Speed compatible)
Power requirements:	AA battery x 2, or USB DC adaptor 5V (not included).
Battery life (Alkaline batteries):	5 hours for recording, or 6 hours for playback (by earphone)
Accessories:	Two lapel microphones, USB cable, two AA batteries, and a headphone.

©American Audio®
American DJ® Group of Companies World Headquarters:
6122 S. Eastern Ave. Los Angeles, CA 90040 USA
Tel: 323-582-2650 Fax: 323-582-2610
Web: www.americanaudio.us E-mail: info@americanaudio.us