

# crystalizer

## Mini Animation Laser

Item ref: 152.747UK

## User Manual

Please read through this manual thoroughly before use, any damage  
Caused by misuse of product will not be covered by warranty.

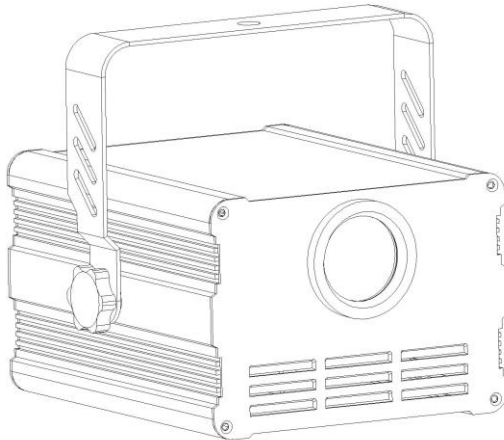

Thank you for choosing the QTX Crystalizer a compact, metal animation laser that produces a crystal clear array of 51 colourful patterns and animations. 5 control modes including auto, sound to light and DMX512 make this versatile, robust unit perfect for any function or event.

### In the box:

Your Crystalizer should arrive with you in a single carton in good condition. The carton should contain 1x main unit with bracket, 1x UK IEC mains lead, 1x laser key and 1x user guide.

### Warning:

To prevent risk of fire or electric shock, do not expose the unit to rain or damp environments. In the event of a spillage, disconnect the mains and allow the unit to dry out naturally. Qualified personnel should then check the unit before continuing use.



**Please do not open cover, contains high voltage. This product is not serviceable or repairable by the end user. Please refer to qualified personnel for service and repair.**



## Caution: Laser radiation

Avoid pointing directly towards eyes. Laser output can cause injury if viewed directly. This product is a Class 3B laser and should only be installed and used by persons who are trained in the management of laser radiation and are able to operate in accordance within the guidance given by the Health and Safety Executive (HSE) in HS(G)95: "The Radiation Safety of Lasers used for Display purposes". Copies of this guide can be downloaded from: [www.avsl.com/assets/documents/hsg95.pdf](http://www.avsl.com/assets/documents/hsg95.pdf)



## Placement:

- Use the included mounting bracket to fix to a stand or lighting truss
- Use secondary safety fixings if mounting overhead.
- Keep away from damp or dusty environments.
- Ensure adequate air-flow around the fixture housings.
- Ensure adequate access to controls and connections.
- Do not aim LED or laser output directly into line of sight, as this can result in eye injury.

## Cleaning:

- Use a soft cloth with a neutral detergent to clean the casing as required.
- Use a vacuum cleaner to clear ventilation grilles of any dust or debris build-ups.
- Do not use strong solvents for cleaning the unit.

## Rear panel controls:

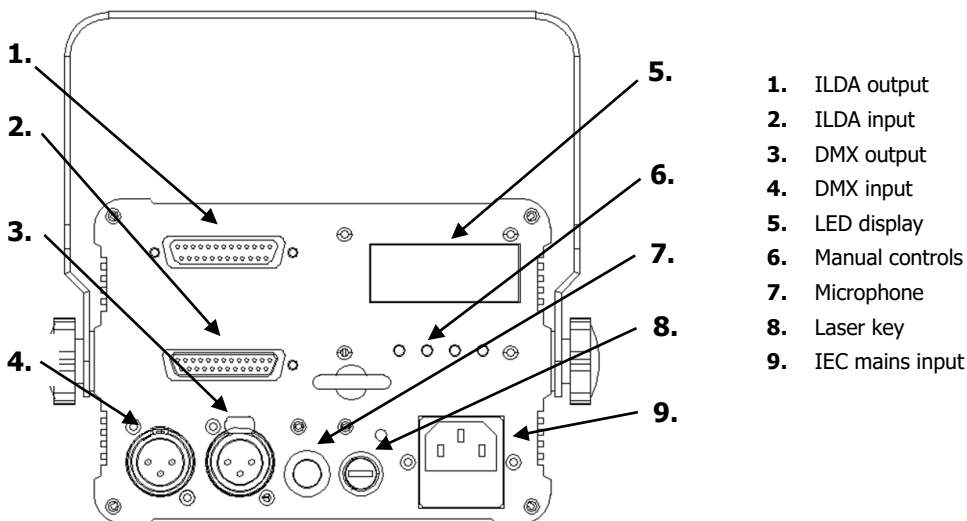

## Manual control menu:

Press the "**MENU**" button to enter the settings menu.

Press "**UP**" and "**DOWN**" buttons to navigate through various setting functions.

Press "**ENTER**" button to confirm the desired setting.

Menu	Function	Description
Addr	A001-A512	DMX address settings
Auto	Aut0-Aut9	Auto mode - slow to fast
SoUn	SoU0-SoU9	Sound to light mode - sensitivity low to high
vEr	vE1.2	Software version 1.2

## DMX modes:

The Crystalizer can be controlled by DMX signal, simply connect the DMX signal source to the DMX input on the unit via a balanced XLR lead. Extra fixtures can be controlled by the same DMX signal by looping through the DMX out on the unit. To enter DMX mode, select A001 from the menu and confirm the correct start address by using the "**UP**" and "**DOWN**" buttons and "**ENTER**". The A on the LED display will begin to flash once it's received the DMX signal from the controller. This unit has 16 DMX channels as indicated in the table below:

### 16-CH (start address A001 for 1st unit, A017 for 2nd unit etc):

Channel	Function	Value	Details
CH1	Laser on/off	0-9	Laser off
		10-99	Laser on
CH2	Colour control	0-69	Fixed colour choice (W, R, B, P, C, Y, G)
		70-79	Whole colour change (chase speed controlled by CH3)
		80-89	Default colour (chase speed controlled by CH3)
		90-99	7 Colours (chase speed controlled by CH3)
		100-224	Segment colour choice (chase speed controlled by CH3)
		225-229	Dynamic colour chase 1 (chase speed controlled by CH3)
		230-234	Dynamic colour chase 2 (chase speed controlled by CH3)
		235-239	Dynamic colour chase 3 (chase speed controlled by CH3)
		240-244	Dynamic colour chase 4 (chase speed controlled by CH3)
		245-249	Dynamic colour chase 5 (chase speed controlled by CH3)
250-255	Dynamic colour chase 6 (chase speed controlled by CH3)		

CH3	Colour chase speed	0-9	No function
		10-127	Colour chase clockwise (slow to fast)
		128-255	Colour chase anticlockwise (slow to fast)
CH4	Pattern selection	0-255	Pattern selection from 5 groups in CH5
CH5	Pattern group selection	0-50	Inner patterns group 1
		51-101	Inner patterns group 2
		102-152	Inner patterns group 3
		153-203	Inner patterns group 4
		204-255	Inner patterns group 5
CH6	Pattern size	0-255	Pattern size manual selection
CH7	Pattern zoom	0-15	Pattern manual zoom
		16-55	Zoom from small to large (slow to fast)
		56-95	Zoom from large to small (slow to fast)
		96-135	Cyclic zoom large to small (slow to fast)
		136-175	Animated cyclic zoom 1 (slow to fast)
		176-215	Animated cyclic zoom 2 (slow to fast)
		216-255	Animated cyclic zoom 3 (slow to fast)
CH8	Centre rotation	0-127	Rotation angle selection
		128-191	Clockwise rotation speed
		192-255	Anticlockwise rotation speed
CH9	Horizontal flip	0-127	Flip horizontal selection
		128-255	Flip horizontal speed
CH10	Vertical flip	0-127	Flip vertical selection
		128-255	Flip vertical speed
CH11	Horizontal move	0-127	Horizontal movement selection
		128-255	Horizontal auto movement (slow to fast)
CH12	Vertical move	0-127	Vertical movement selection
		128-255	Vertical auto movement (slow to fast)
CH13	Wave effect	0-9	No function
		10-255	Wave range and speed selection (small to large and slow to fast)

CH14	Pattern drawing	0-1	No function
		2-63	Manual drawing 1
		64-127	Manual drawing 2
		128-153	Auto drawing (increase)
		154-179	Auto drawing (decrease)
		180-205	Auto drawing (increase to decrease & erase)
		206-255	Auto drawing (increase to decrease cyclical)
CH15	Inner dynamic effect	0-2	No function
		3-229	Single group dynamic effect (speed and colour controlled by CH16)
		230-249	Random auto effect (speed and colour controlled by CH16)
		250-255	Sound activated auto effect
CH16	Inner dynamic effect speed	0-127	Inner effect speed auto (slow to fast)
		128-255	Inner effect speed DMX (slow to fast)

### Specifications:

<b>Power supply</b>	110-240Vac, 50/60Hz (IEC)
<b>Power consumption</b>	22W (max)
<b>Fuse rating</b>	F2A
<b>Laser power</b>	1000mW
<b>Laser Class</b>	3B
<b>DMX channels</b>	16
<b>Modes</b>	Auto/Sound/DMX512/Master-Slave
<b>Connections</b>	IEC power, DMX in/out (XLR), Laser key, ILDA in/out
<b>Dimensions</b>	188 x 193 x 173mm
<b>Weight</b>	2.21kg

### Troubleshooting:

No power (mains)	Check mains voltage is correct and outlet is switched on
	Check IEC lead and fuse (if fuse continually blows, refer to your dealer)
No laser or light output	Check control panel mode settings
	Check DMX settings from controller (dimmer levels, blackout etc.)
	Check laser key on rear panel is turned on
Unresponsive to DMX	Check that unit is in DMX mode and ensure the A on the DMX

	address flashes to confirm it's receiving a DMX signal
	Check DMX controller is on correct fixture/page
	Check master dimmer value
	Check correct DMX address is set
	Check DMX connection and leads
Overheating/ cutting out	Ensure adequate ventilation and unit is not too close to a heat source



This product is classed as Electrical or Electronic equipment and should not be disposed with other household or commercial waste at the end of its useful life. The goods must be disposed of according to your local council guidelines.

**Errors and omissions excepted.**

Copyright© 2022 AVSL Group Ltd, Unit 2 Bridgewater Park,  
Taylor Road, Trafford Park, Manchester. M41 7JQ.

AVSL (Europe) Ltd, Unit 3D North Point House,  
North Point Bus. Park, New Mallow Road, Cork, Ireland.