

RM1202

Rackmount 2-zone Mixer-Amplifier

Item ref: 953.163UK

User Manual

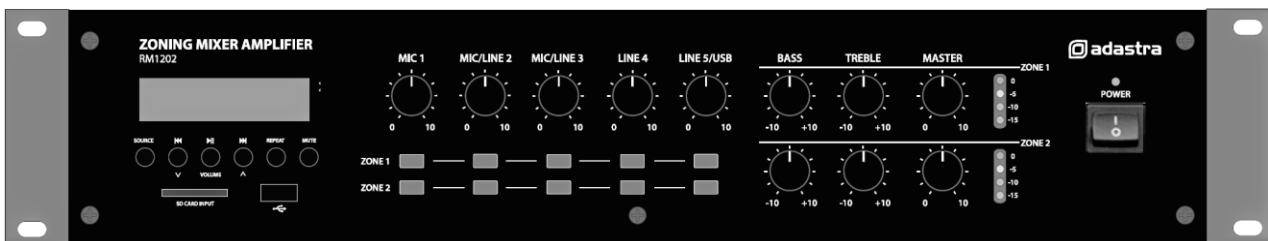

Version 2.1



Caution: Please read this manual carefully before operating
Damage caused by misuse is not covered by the warranty

Introduction

Thank you for choosing the Adastra RM1202 rackmount 2-zone mixer-amplifier as part of your public address system. This unit is designed to offer high quality, dependable service for mobile and installed systems. Please read this manual to gain the best results from your product and avoid damage through misuse.

SAFETY SYMBOL AND MESSAGE CONVENTIONS



CAUTION
RISK OF ELECTRIC SHOCK
DO NOT OPEN

AVIS
RISQUE DE CHOC ELECTRIQUE NE PAS
OUVRIR



This symbol indicates that dangerous voltage constituting a risk of electric shock is present within this unit



This symbol indicates that there are important operating and maintenance instructions in the literature accompanying this unit.



SAFETY NOTICE

1. Prior to use, read through this manual
2. Keep the manual in good condition
3. Pay attention to safety warnings
4. Observe all operating requirements
5. Do not use the device near water or wet areas
6. For cleaning, only use a lint-free, dry cloth
7. Install according to the specifications
8. Place away from heat sources or heating appliances
9. Use mains lead provided and avoid damage to cable or connectors
10. Unplug power from mains during stormy weather or if unused for long periods
11. In case of malfunction, water ingress or other damage, consult qualified service personnel
12. Do not place in damp areas or near liquids or moisture. Do not spill liquids on the housing
13. Please pay attention to warning symbols during transit and placement
14. Terminals marked with the $\frac{1}{2}$ symbol are HAZARDOUS LIVE and should only be connected by qualified personnel
15. Ensure that the apparatus is connected to a mains socket with a protective EARTH connection
16. Ensure correct operation of the mains switch

Warning

To prevent the risk of fire or electric shock, do not expose any components to rain or moisture.

If liquids are spilled on the casing, stop using immediately, allow unit to dry out and have checked by qualified personnel before further use. Avoid impact, extreme pressure or heavy vibration to the case

No user serviceable parts inside – Do not open the case – refer all servicing to qualified service personnel.

Safety

- Check for correct mains voltage and condition of IEC lead before connecting to power outlet
- Use double insulated speaker wire with adequate current rating for 100V speaker connections
- Only use 1 type of output per zone – i.e. 4Ω, 8Ω or 100V – do not mix or combine these outputs on a single zone
- Do not connect 4Ω or 8Ω speakers to the 100V terminal or 100V speakers to the 4Ω or 8Ω terminals
- Do not allow any foreign objects to enter the case or through the ventilation grilles

Placement

- For rack-mounting, ensure adequate support for the weight of the amplifier
- Ensure adequate air-flow and do not cover cooling vents at the sides of the amplifier
- Ensure adequate access to controls and connections

Cleaning

- Use a soft cloth with a neutral detergent to clean the casing as required
- Use a vacuum cleaner to clear ventilation grilles of any dust or debris build-ups
- Do not use strong solvents for cleaning the unit

Front panel

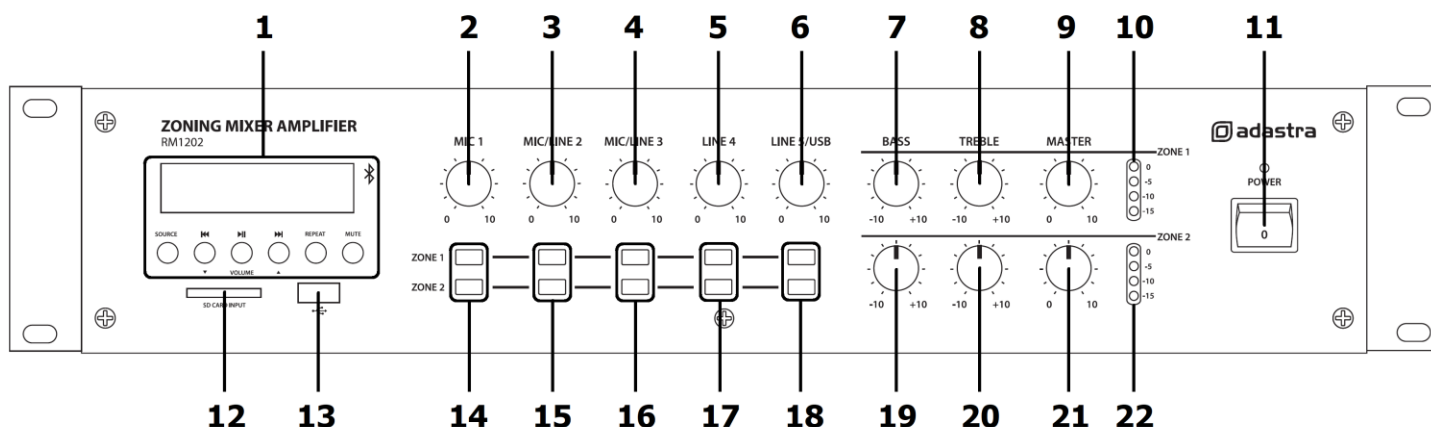

- | | |
|--|---|
| 1. Media player | 12. SD card slot |
| 2. Mic 1 level control | 13. USB port |
| 3. Mic/Line 2 level control | 14. Mic 1 zone assign buttons |
| 4. Mic/Line 3 level control | 15. Mic/Line 2 zone assign buttons |
| 5. Line 4 level control | 16. Mic/Line 3 zone assign buttons |
| 6. Line 5 / Media Player level control | 17. Line 4 zone assign buttons |
| 7. Zone 1: Bass EQ | 18. Line 5 / Media Player zone assign buttons |
| 8. Zone 1: Treble EQ | 19. Zone 2: Bass EQ |
| 9. Zone 1: Master Volume | 20. Zone 2: Treble EQ |
| 10. Zone 1: Level Indicator LEDs | 21. Zone 2: Master Volume |
| 11. Power on/off switch & LED | 22. Zone 2: Level Indicator LEDs |

Rear panel

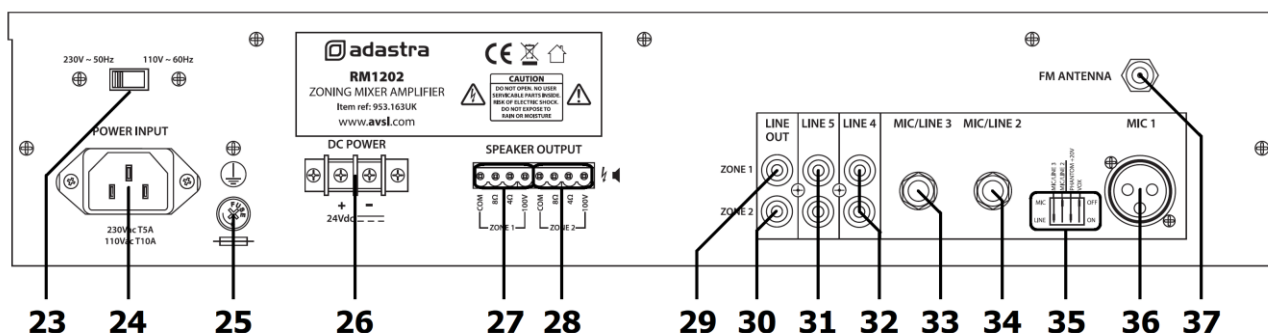

- | | |
|-------------------------------------|-----------------------------------|
| 23. Voltage selector | 31. Line 5 input (2 x RCA) |
| 24. Mains power inlet (IEC) | 32. Line 4 input (2 x RCA) |
| 25. Mains fuse holder | 33. Mic/Line 3 input (6.3mm jack) |
| 26. 24Vdc power terminals | 34. Mic/Line 2 input (6.3mm jack) |
| 27. Zone 1 speaker output terminals | 35. DIP switches |
| 28. Zone 2 speaker output terminals | 36. Mic.1 input (XLR) |
| 29. Zone 1 Line output | 37. FM antenna connector |
| 30. Zone 2 Line output | |

Introduction

The RM1202 is a versatile and powerful mixer amplifier with 5 input channels which are assignable to 2 independent zone outputs. In addition to external signal sources, the RM1202 has an integrated Bluetooth™ receiver, FM tuner and USB/SD audio player for comprehensive audio playback options. Please read the following instructions to get the best results from the equipment and avoid damage through misuse.

Connection and setup

With the RM1202 power switched off (11), connect the rear IEC inlet (24) to the mains using the supplied mains lead (or an equivalent approved type). Ensure that the voltage is correct as indicated on the voltage selector (23) and that the mains outlet is switched on.

Alternatively, the RM1202 can be operated by 24Vdc power for mobile applications (boats, fairgrounds etc.) For this type of application, connect the 24Vdc power source to the DC input terminals on the rear panel (26)

The RM1202 has 5 input channels and an integral multi-source audio player.

Channel 1 is a dedicated microphone input via a balanced XLR connector with switchable priority.

Channels 2 and 3 are designed for either microphones or line level sources (such as a CD/mp3 player or output from a mixer) via 6.3mm jack connectors on the rear panel.

Channels 4 and 5 are line inputs via RCA connectors with channel 5 shared by the onboard media player. An antenna 'F' connector (37) is provided on the rear panel for connection to an external aerial for FM tuning.

DIP switches

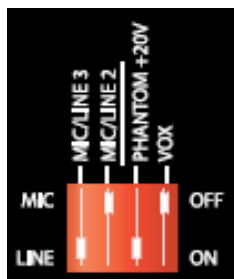

Adjacent to the XLR microphone input for channel 1 is a bank of 4 DIP switches (35). The right-hand switch is marked 'VOX', which sets priority for Mic.1. When this is switched on, any sound through Mic.1 will temporarily mute other inputs.

The next DIP switch enables +20V phantom power on the Mic.1 XLR input. Some condenser microphones require this phantom power to operate.

The 2 remaining DIP switches are used to set channels 2 and 3 to Mic or Line level.

Be sure to make these DIP switch settings when the amplifier is switched off. Making any changes when the amplifier is powered up may cause loud bangs through the system which can damage the speakers.

Signal Inputs and Outputs

Connect the main paging microphone to Mic.1 XLR input (36) and enable phantom power if required.

Connect microphones or line signals to Mic/Line 2 and 3 inputs (33, 34) using good quality jack leads.

Line level sources can be connected to Line 4 and 5 RCA inputs (31, 32)

Zone 1 and Zone 2 have individual RCA signal outputs on the rear panel (29, 30), which can be connected to the line inputs of active speakers or amplifiers. These are in addition to the speaker outputs detailed below.

Stereo operation

Both RCA connectors for Line 4 and Line 5 inputs are summed together to merge the stereo signal into mono. This is useful for installed systems where the complete music mix needs to go to every speaker.

The RM1202 can also be used as a stereo 100V amplifier by connecting a Left line input to Line 4 enabled to Zone 1 and Right line input to Line 5 enabled to Zone2. This would produce a left output to Zone 1 and Right output to Zone 2.

Speaker outputs

The RM1202 has a separate speaker output for each zone (27, 28) connected via a single terminal block. The block is removable to enable easy access to the screw terminals.

Each zone output can be used to power either 100V line speakers or standard 4Ω or 8Ω speakers. These configurations cannot be used together, so it is important to decide which will be used at the start.

100V line systems

For 100V speakers, connect the selected zone output to the first speaker in the zone using double-insulated speaker wire which has adequate current rating to handle the total output of the amplifier.

Connect the "100V" output terminal for the selected zone to the positive (+) connection of the speaker and "COM" output to the negative (-) connection of the speaker. Connect further speakers in parallel to the first speaker with all positive terminals and connected together and all negative terminals connected together as shown below.

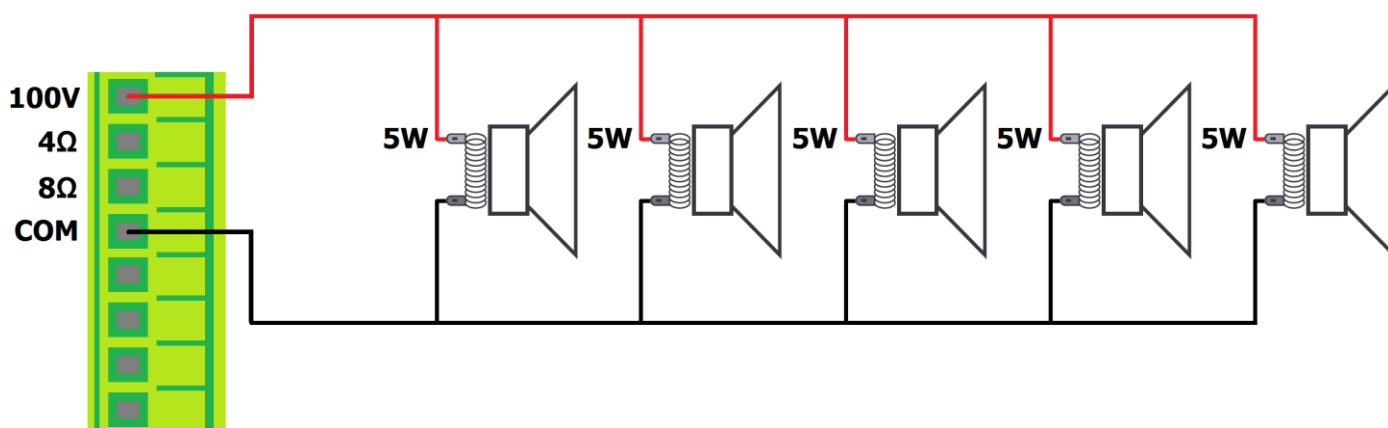

A 100V line speaker system can comprise of many speakers connected together. The determining factor for how many speakers can be used on a single amplifier is the power rating. For most purposes, it is advised to connect as many speakers as needed with a combined wattage of no more than 90% of the amplifier's output power rating (in the case of the RM1202, this is 120W per zone output)

The terminals of a 100V speaker are connected via a transformer and in some cases, this transformer may be "tapped" for different power ratings. These tapings can be used to adjust the wattage (and output volume) of each speaker in a zone to help achieve the ideal total power of the system for the relevant zone output.

Low impedance systems

Alternatively, each zone output of the RM1202 is capable of powering one or more low impedance speakers. There is an option on each zone for either a 4Ω or 8Ω speaker output to determine the minimum impedance. It is essential to select the correct output terminal when opting for low impedance speakers.

For a single 8Ω speaker, connect the positive (+) wire to the "8Ω" terminal and the negative (-) wire to "COM"

For a single 4Ω speaker or for 2 x 8Ω speakers connected in parallel, connect the positive (+) wire to the "4Ω" terminal and the negative (-) wire to "COM"

In either case, the connected load should have a combined impedance no lower than stated on the terminal. Lower impedance may cause irreparable damage to the amplifier.

The connected speaker(s) must also have a power handling to accept up to 120Wrms from the zone output. Lower power handling may risk damage to the speakers.

Operation

When all connections to the amplifier are made, turn all rotary controls down and switch on the power (11). The power LED will illuminate. To check for correct operation of the system, select an input source and output zone for testing. In the following example, Mic.1 input and Zone 1 output have been selected.

- Turn the Zone 1 Bass and Treble rotary controls (7, 8) to the vertical (12 o'clock) position
- Turn up Zone 1 Master volume control (9) part way for testing
- Make sure that the Zone 1 assign button for Mic.1 channel (14) is pressed in
- Speak into the microphone connected to the Mic.1 input (36)
- Gradually turn up the Mic.1 level control (2) whilst checking the LED indicators for Zone 1 (10)
- The microphone should now be audible through loudspeakers connected to the Zone 1 speaker output.
- Increase the Zone 1 output level to the maximum required volume for that zone
- Reduce the Mic/Line level to compensate

The above process can be extended to check all other input channels.

If preferred, the system can be checked using the onboard multi-source audio player.

Full information on the operation of this feature is detailed below.

Repeat the above process for Zone 2 to check output to the speakers from the enabled input channels.

Each zone has Bass and Treble controls to adjust the tonal content.

Bass controls the low frequency content and Treble controls the high frequency content.

The vertical (12 o'clock) position is neutral, rotating to the left is cut and to the right is boost.

Adjust both controls for each zone to give the desired tonal character to the connected speakers.

Media player

The RM1202 is fitted with a built-in media player, which allows playback of music or audio messages stored as standard compressed audio files on either USB pen drive or SD card.

The media player also has an FM radio tuner function and Bluetooth receiver as described below.

The output level of the media player is controlled by the LINE 5/USB control (6) on the front panel.

SOURCE	USB / SD / FM tuner / Bluetooth input source selector
⏪	Previous track or FM channel / volume down
▶	Play or pause current track / auto tune FM stations
⏩	Next track or FM channel / volume up
REPEAT	Repeat mode – off, single track or all
MUTE	Mute media player output

USB/SD

Push a USB pen drive into the USB port (13) and/or SD card into the SD card input (12) and the audio files will start to play automatically. Turn up the MEDIA control gradually to hear the output from the speakers and increase to the required level.

If play does not start automatically, press the SOURCE button and Play/Pause button (▶ ||) to check if the player is set to play from the required memory device. If playback still does not start, try pressing the Previous track and Next track buttons (⏪, ⏩). Otherwise, check that the audio files are standard compressed type.

Normal playback will read through all tracks on the storage device. Pressing the REPEAT button will step through the repeat modes.

RT1 = repeat current track RND = random play RTA = repeat all tracks

Pressing the Previous track button (⏪) briefly steps backwards through tracks on the memory device. Press and hold this button to decrease the playback volume.

Pressing the Next track button (▶▶) briefly steps forwards through tracks on the memory device. Press and hold this button to increase the playback volume.

To pause the current track, press the Play/Pause button (▶ ||) and press again to resume playback. The LCD display will show the selected track number and then the elapsed time during playback.

FM Tuner

Press the Source button to switch to the FM tuner function. For good FM reception, it will be necessary to connect an external aerial to the Antenna connector on the rear panel using good quality coaxial RF cable terminated with an F-type connector.

To auto-tune available stations, press and hold the Play/Pause button to begin auto tuning, which scans available stations and automatically stores them as channels within the FM tuner.

Alternatively, to tune the station presets manually, press the Play/Pause button briefly to enter manual tuning mode (MANU). Use Previous/Next track buttons to select the desired frequency and press REPEAT, then use Previous/Next track buttons to select the preset and press REPEAT again to store the frequency in that preset (display will show "OK"). Repeat for all ten presets P01 to P10.

Press MUTE to exit the manual tuning mode.

To step through pre-set stations, press the Previous or Next buttons.

Hold down the REPEAT button to delete a stored station.

Holding the Previous track or Next track buttons will adjust the output volume of the player.

Bluetooth

The Bluetooth function allows connection of a smart phone or tablet to the media player section for playback of stored files or streamed digital audio.

In order to enable this function, it will be necessary to pair the sending device to the receiver as follows.

1. Open the Bluetooth settings menu on the smart phone or tablet (or other sending device)
2. Scan for Bluetooth devices and look for "adastra 0000" in the list of available devices (ensure that the RM amp is powered on and within reception range)
3. Select "adastra 0000" and the sending device should confirm that it is connected as an audio device. (note that "0000" may be a different number if it has been edited – see below)
4. Play audio from the sending device, ensuring that volume controls are not turned down/muted
5. Turn up the LINE 5/USB volume control on the amplifier to the required level.

The Previous, Next and Play/pause buttons will operate in Bluetooth as remote playback controls. Holding the Previous track or Next track buttons will adjust the output volume of the player.

The Bluetooth name can be customized to enable identification of individual nearby amplifiers.

To customize the Bluetooth number press and hold the Play/Pause button until adastra 0000 is displayed with one of the characters flashing. Press Previous or Next buttons to edit the number and Play/Pause to select another character. Hold Play/Pause to store the ID and exit.

Note: Android devices have the facility to re-name devices within the Bluetooth settings menu.

If the Bluetooth ID has been re-named on the Android device, editing the Bluetooth ID on the media player will not affect the name displayed on that Android device.

Track navigation can be controlled from the paired device or from the front panel of the RM1202.

Previous, Next and Play/pause buttons (◀◀, ▶▶, ▶ ||) will operate in Bluetooth as remote playback controls.

Holding down the Previous or Next buttons will also adjust the volume of the player.

Specifications

Power supply	110-230Vac, 50/60Hz (IEC)
Output power	2 x 120Wrms
Audio source	USB/SD/FM/BT audio player
Bluetooth version	2.0
Inputs	1 x mic (XLR), 2 x mic/line (6.3mm jack), 2 x line (twin RCA)
Input impedance	1k Ω (mic/line)
Input sensitivity	-11dB (line), -46dB (mic)
Zone outputs: line	2 x RCA
Zone outputs: speaker	2 x terminal outputs 100V/8 ohms/4 ohms/com
Zone controls	Bass, Treble, Master volume
Phantom power	+20V switchable to Mic.1 XLR
Frequency response	100Hz - 20kHz
THD	<0.76% @ 1kHz
SNR	84dB (line), 82dB (mic)
Dimensions	433 x 88 x 320mm
Weight	11.24kg

Troubleshooting

No power LED on control panel	Ensure IEC lead is in good condition and connected properly
	Ensure that the voltage selector is switched to the correct value for the supply
	Ensure POWER switch is on and check mains inlet fuse
Power LED is on but no other LEDs and no output	Check input signals and condition of input connection leads
	Check that the selected zone output is assigned on the active input channel
	Ensure that Zone Master, Mic, Line or media player volume controls are turned up
Power light and zone indicator LEDs lighting but no output	Check speaker output terminals are connected correctly
	Check speakers are working (test on another amp if available)
LCD display on audio player is not lit	If main power is on, press and hold the Mute button until the display is lit
No output from audio player	Ensure that Mute function is off and volume is not set too low (press and hold "∧")
	Check that Mic.1 priority is not overriding playback
No playback via Bluetooth	Ensure that the sending device is paired and connected as audio to the correct device
	Check the playback status and volume setting of sending device
USB/SD player will not play audio from media	Press Play/Pause button to ensure track is not paused
	Press the Source button to ensure that the required device is selected
	Check memory device is connected properly (remove and re-insert)
	Check file types – standard compressed digital audio files are required
Output is very loud or distorted	Check level of input signal is not too high
	Reduce level control for Mic, Line or media player input
	Reduce any boost to Bass or Treble and reduce Master volume control if needed
Output is working but at very low level	Check input audio source level is not too low
	Increase Master volume and input channel controls and remove any Bass or Treble cut
	Check for quiet recording of media files on USB/SD/BT devices
	Check Mic.1 priority is not unintentionally suppressing other channels
No microphone output	Check phantom power is enabled if using condenser microphones
Feedback from microphone	Face microphone away from speakers
	Turn down Mic level control
Amplifier overheating	Ensure cooling vents are clear from debris and dust
	Check that 4 Ω or 8 Ω speakers are not connected to 100V terminals
	Ensure total 100V speaker wattage is lower than the max rating for any zone
	Ensure that 100V and 8 Ω speakers are not connected simultaneously
	Ensure that total load connected to 4 Ω or 8 Ω output is not less than stated



Disposal: The "Crossed Wheelie Bin" symbol on the product means that the product is classed as Electrical or Electronic equipment and should not be disposed with other household or commercial waste at the end of its useful life. The goods must be disposed of according to your local council guidelines.

*Errors and omissions excepted.
Copyright© 2019. AVSL Group Ltd.*