

# OPERA UNICA 15

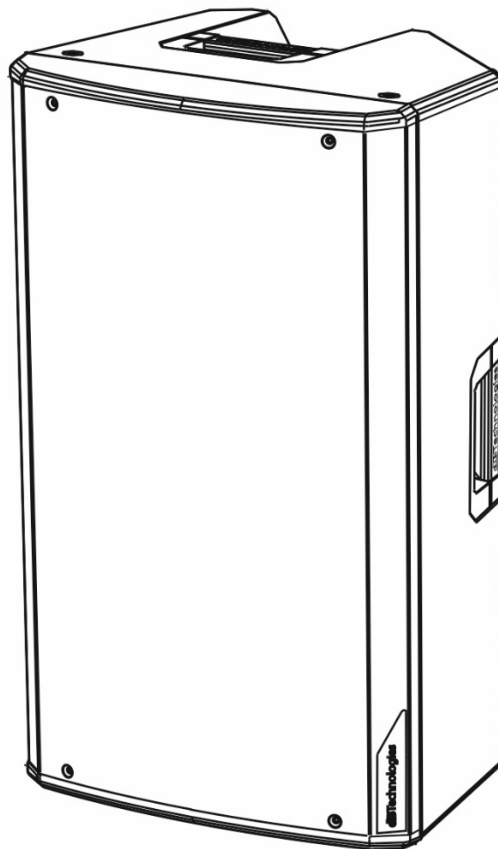

## Quick start user manual *Section 1*

The warnings in this manual must be observed together with the "USER MANUAL - Section 2".

Le avvertenze nel presente manuale devono essere osservate congiuntamente al "MANUALE D'USO - Sezione 2".

Die Warnungen in diesem Handbuch müssen in Verbindung mit der "BEDIENUNGSANLEITUNG - Abschnitt 2" beobachtet werden".

Les avertissements spécifiés dans ce manuel doivent être respectés ainsi que les "CARACTERISTIQUES TECHNIQUES - Section 2".

Las advertencias del presente manual se deben tener en cuenta conjuntamente con las del "MANUAL DEL USUARIO" - Sección 2".

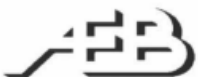

A.E.B. Industriale Srl Via Brodolini, 8 Località Crespellano 40053 VALSAMOGGIA BOLOGNA (ITALIA)  
Tel +39 051 969870 Fax +39 051 969725 [www.dbtechnologies.com](http://www.dbtechnologies.com) info@dbtechnologies-aeb.com



## Thank you for choosing a dBTechnologies Product!

The new OPERA UNICA 15 is a lightweight and versatile active speaker, designed for the use in live or installed scenarios. It is equipped with one 1" compression driver (1.75" voice coil), and one 15" neodymium woofer (3" voice coil). The dispersion pattern is asymmetrical on vertical axis, and it is diversified (top and bottom) on the horizontal one. This allows a good coverage also in case of reverberant environment. The amplifier (900 W RMS) is controlled by a powerful DSP, which use FIR filters in audio real-time processing. Eight presets are available for different equalization settings, in stacked or wedge use. Various optional accessories are available for all configuration needs. RDNNet connections enhance the control possibilities also in complex scenarios (for example in multiple installations).

Check the site [www.dbtechnologies.com](http://www.dbtechnologies.com) for the complete user manual!

### 1) Unpacking

The box contains:

No. 1 OPERA UNICA 15

No. 1 fuse

No. 1 Mains cable

This quick start and warranty documentation

### 2) Easy installation

OPERA UNICA 15 is equipped with:

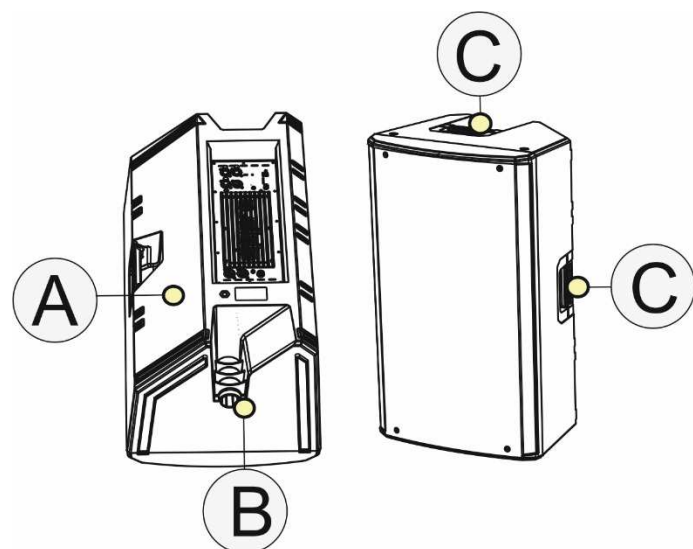

Tilted side (A) for monitor (wedge) positioning

Pole mount (36 mm) (B) for tripod stand mounting

Upper and side (C) handles, which allow an easy displacement

a) vertical coverage: 85° asymmetrical (+25°/-60°)

b) horizontal coverage: 110° (85° in the upper part, 120° in the lower one)

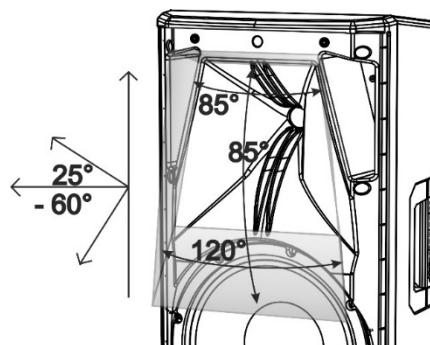

The main admitted configurations, thanks also to various accessories like wall bracket WB-OP15, as shown in the picture below, are:

X – on a tripod stand (the maximum admitted height from floor and the base of loudspeaker is 1,6 m)

Y – with wall bracket in truss mounting (via aliscaff)

Z – wall mounted

W – wedge (monitor configuration on the stage)

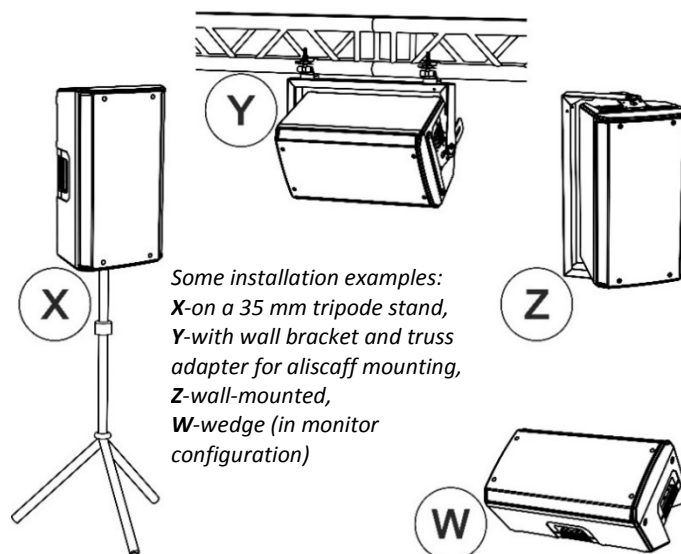

Some installation examples:  
 X-on a 35 mm tripod stand,  
 Y-with wall bracket and truss adapter for aliscaff mounting,  
 Z-wall-mounted,  
 W-wedge (in monitor configuration)



**NEVER USE THE HANDLES TO SUSPEND THE SPEAKER!**

The dispersion pattern is asymmetrical on the vertical axis, and the horizontal coverage varies within position: It is wider in the lower side and narrow in the upper one.

As shown in the following picture, the related dispersion pattern data are:

For further information about accessories and admitted configurations, please refer to the complete user manual.

### 3) Connections and controls

All the connections and controls are in the amplifier panel side:

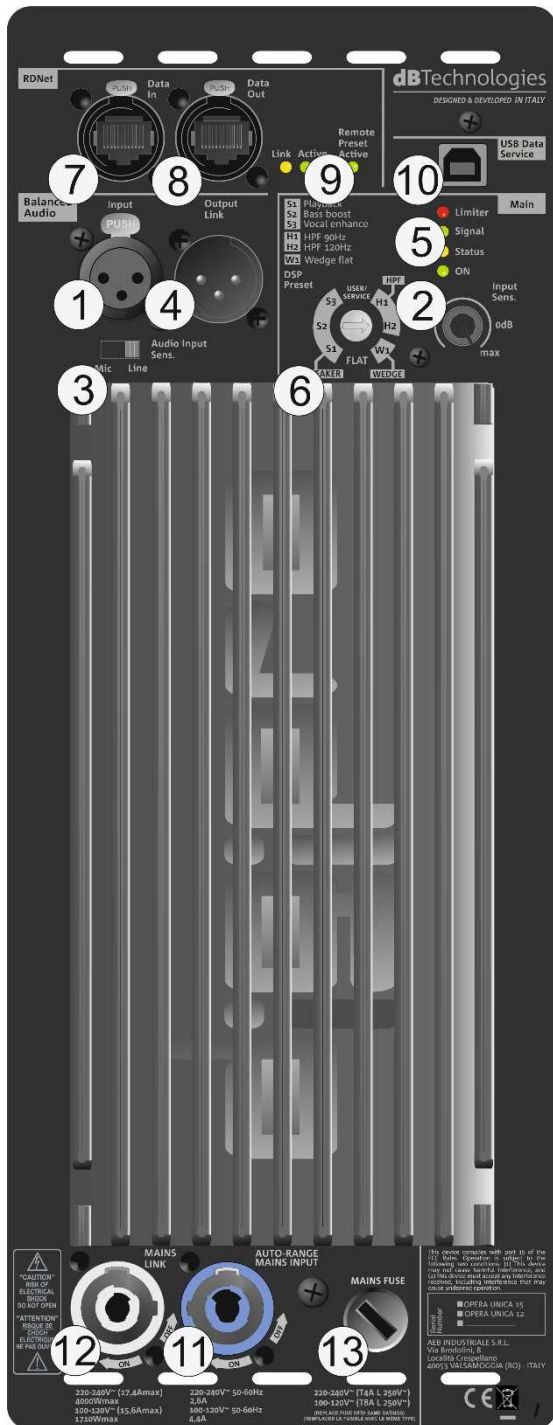

- 1-Balanced input (XLR connector type)
- 2-Input sensitivity control
- 3-Input sensitivity type switch (MIC/LINE)
- 4-Balanced output Link (XLR connector type)
- 5-Status LEDs (Limiter-Signal-Status-ON)
- 6-DSP Preset rotary with reference table
- 7-RDNet DATA IN
- 8-RDNet DATA OUT
- 9-RDNET control LEDs
- 10-USB Data Service
- 11-Auto-range Mains Input
- 12-Mains Link
- 13-Mains Fuse

a) Connect the audio input [1]. In case of dynamic microphone, select “MIC” in input sensitivity switch [3], otherwise select “LINE”. Adjust the Input Sensitivity level [2].

b) If you need to send the audio signal to a second speaker, connect the “Balanced Output” [4] to the Input on [1] of another OPERA UNICA 15 (for example) using a cable with XLR (balanced) connector.

c) Set properly the DSP preset rotary [6], choosing between on stand “S”, wedge “W” configurations, or apply HPF filters “H”. The settings possibilities are:

- S1- Playback, for tracks (like mp3 reproduction)
- S2- Bass boost, with a low-frequencies enhancement
- S3- Vocal enhance, for an optimization in vocal and singing performances
- H1 - HPF 90 Hz - Apply high-pass filter with 90 Hz cutoff frequency, for a little bass reduction
- H2 - HPF 120 Hz - Apply high-pass filter with 120 Hz cutoff frequency, for a strong bass reduction
- W1- Wedge, designed for reproduction in monitoring (wedge) use
- FLAT - designed for coherent source reproduction

d) In case of remote control, connect the proper Data Input [7] to the hardware remote controller (RDNet Control 2 or RDNet Control 8) with cables equipped with etherCON connectors. Then connect the Data Output [8] to the Data Input [7] of a second OPERA UNICA, and so on. When the RDNet network is on and it has recognized the connected device, the LED “Link” [9] is on. The other LED [9] “Active” start blinking when there is the presence of data transmission, the “Remote Preset Active” advise that all the local controls set on the amplifier panel (level, DSP presets, etc.) are by-passed and controlled remotely by AURORA NET software. See also RDNet Control 2, RDNet Control 8 and AURORA NET user manuals for further information.

e) Plug the mains Input [11] and Link [12] (powerCON) cables. The Signal/ON led starts blinking, signaling the presence of audio signal.

**WARNING**  
**The speaker is supplied with a mounted fuse for operation within the 220-240V~ range. If you need to operate in the 110-120V~ voltage range:**

1. Disconnect all connections, including the power supply.
2. Wait for 5 minutes.
3. Replace the fuse with the one provided in the package for the 100-120V~ range

Check the complete user manual on [www.dbtechnologies.com](http://www.dbtechnologies.com) for further information about the system and available accessories. Scarica il manuale completo da [www.dbtechnologies.com](http://www.dbtechnologies.com) per ogni ulteriore informazione sul sistema e sugli accessori disponibili. Für weitere Informationen und verfügbares Zubehör lesen sie bitte die vollständige Bedienungsanleitung unter [www.dbtechnologies.de](http://www.dbtechnologies.de). Vérifiez le manuel de l'utilisateur complet sur [www.dbtechnologies.com](http://www.dbtechnologies.com) pour des informations complémentaires du système et des accessoires disponibles. Compruebe el manual de usuario completo sobre [www.dbtechnologies.com](http://www.dbtechnologies.com) para la información adicional sobre el sistema y accesorios disponibles.

## Technical Data

**Speaker Type:** 2-way active speaker  
**Usable Bandwidth [-10 dB]:** 57 – 20000 Hz  
**Frequency Response [-6 dB]:** 61 – 20000 Hz  
**Max SPL (1 m):** 133 dB  
**HF compression driver:** 1 " Exit  
**HF voice coil:** 1.75"  
**LF:** 15" (Neodymium)  
**LF Voice Coil:** 3"  
**Crossover frequency:** 1600 Hz  
**FIR filters:** yes  
**Horizontal dispersion:** 110° (85° up / 120° down)  
**Vertical dispersion:** 85° (+25° / -60°)

## Amplifier

**Amp Technology:** Digipro® G3 Auto-range  
**Amp Class:** Class-D  
**RMS Power:** 900 W  
**Peak Power:** 1800 W

## Operating voltage:

220-240V~ (50-60 Hz) or 100-120V~ (50-60 Hz)



Scan with your QR Reader  
App to download the  
complete User Manual

Download the complete user manual on:

[www.dbtechnologies.com/EN/Downloads.aspx](http://www.dbtechnologies.com/EN/Downloads.aspx)

## EMI CLASSIFICATION

According to the standards EN 55103 this equipment is designed and suitable to operate in E3 (or lower E2, E1) Electromagnetic environments.

### FCC CLASS B STATEMENT ACCORDING TO TITLE 47, PART 15, SUBPART B, §15.105

This equipment has been tested and found to comply with the limits for a Class B digital device, pursuant to part 15 of the FCC Rules.

These limits are designed to provide reasonable protection against harmful interference in a residential installation.

This equipment generates, uses and can radiate radio frequency energy and, if not installed and used in accordance with the instructions, may cause harmful interference to radio communications.

However, there is no guarantee that interference will not occur in a particular installation. If this equipment does cause harmful interference to radio or television reception, which can be determined by turning the equipment off and on, the user is encouraged to try to correct the interference by one or more of the following measures:

1. Reorient or relocate the receiving antenna.
2. Increase the separation between the equipment and receiver.
3. Connect the equipment into an outlet on a circuit different from that to which the receiver is connected.
4. Consult the dealer or an experienced radio/TV technician for help.

Changes or modifications not expressly approved by the party responsible for compliance could void the user's authority to operate the equipment.

**WARNING:** Make sure that the loudspeaker is securely installed in a stable position to avoid any injuries or damages to persons or properties. For safety reasons do not place one loudspeaker on top of another without proper fastening systems. Before hanging the loudspeaker check all the components for damages, deformations, missing or damaged parts that may compromise safety during installation. If you use the loudspeakers outdoor avoid spots exposed to bad weather conditions.

Contact dB Technologies for accessories to be used with speakers. dBTechnologies will not accept any responsibility for damages caused by inappropriate accessories or additional devices.

*Features, specification and appearance of products are subject to change without notice.*

*dBTechnologies reserves the right to make changes or improvements in design or manufacturing without assuming any obligation to change or improve products previously manufactured.*

## Processor

**Controller:** 56 bit DSP, 24 bit/48 kHz AD/DA converter  
**Limiter:** Peak, RMS, Thermal  
**Controls:** DSP rotary control (8 presets), Input sensitivity switch, input sensitivity level

## Input/Output

**Mains/link connections:** powerCON® type  
**Signal Input/Link:** Balanced XLR type  
**RNet connections:** Data in, Data out  
**Daisy chain power connection (max number of OPERA UNICA 15):** 6 (1+5) (220-240V~) / 3 (1+2) (100-120V~)

## Mechanics

**Housing:** Polypropylene  
**Grille:** Full grille  
**Rigging points:** (2x) M10 on top + (1x) M10 on the rear  
**Pole Mount:** yes, 36 mm diameter  
**Width:** 420 mm (16.54 in)  
**Height:** 722 mm (28.43 in)  
**Depth:** 419 mm (16.50 in)  
**Weight:** 18.2 kg (40.12 lbs.)

## POWER SUPPLY SPECIFICATIONS (POWER ABSORPTION)

Draw at 1/8 of full power in average use conditions (\*): 1.3 A (220-240V~) - 2.1 A (100-120V~)

Draw at 1/3 of full power in maximum use conditions (\*\*): 2.6 A (220-240V~) - 4.4 A (100-120V~)

Power absorption with speaker turned on without signal (idle): 19 W

\* INSTALLER NOTES: The values refer to 1/8 of full power, in average operating conditions (music program with infrequent or no clipping). It is recommended to consider them the minimum sizing values for any type of configuration.

\*\* INSTALLER NOTES: The values refer to 1/3 of full power, in heavy operating conditions (music program with frequent clipping or activation of the limiter). We recommend sizing according to these values in case of professional installations and tours.