

KAM

INSTRUCTION MANUAL

Power Partybar WFS

Powerful LED DMX lighting system

M A N U A L V E R S I O N 1 . 0
1 7 . 0 6 . 1 5

For the latest instruction manual updates and information on the entire Kam range visit:

www.kam.co.uk

Kam products are manufactured by: **Lamba plc**, Unit 1, Southfields Road, Dunstable, Bedfordshire, United Kingdom LU6 3EJ
Telephone: (+44) (0)1582 690600 • Fax: (+44) (0)1582 690400 • Email: mail@lambapl.com • Web: www.lambapl.com

If this product is ever no longer functional please take it to a recycling plant for environmentally friendly disposal.

Due to continuous product development, specifications and appearance are subject to change.

© Copyright Lamba plc. E&OE.

Thank you for purchasing this Kam product, we are sure that it will serve you for many years to come.

To optimise its performance, please read these instructions carefully to familiarise yourself with the basic operations of the unit. Please retain them for future reference. This unit has been tested at the factory before being shipped to you. To prevent or reduce the risk of electrical shock or fire, do not expose the unit to rain or moisture. To prevent a fire hazard, do not expose the unit to any naked flame sources. Unplug this apparatus during lightning storms or if it is unlikely to be used for long periods of time.

When installing the unit, please ensure you leave enough space around the unit for ventilation. Slots and openings in the unit are provided for ventilation to ensure reliable operation of the product and to protect it from overheating. To prevent fire hazard, the openings should never be blocked or covered.

The unit is powered by the mains, always handle the power cable by the plug. Never pull out the plug by pulling on the cable. Never touch the power cable when your hands are wet as this could cause an electric shock. Do not tie a knot in the cable. The power cable should be placed such that it is not likely to be stepped on. A damaged power cable can cause a fire or give you an electrical shock. Check the power cord periodically, if you ever find that it is damaged, replace it before using the unit again. Contact your retailer for a replacement.

The voltage of the available power supply differs according to country or region. Be sure that the power supply voltage of the area where this unit is to be used meets the requirements of the unit.

The lightning flash symbol inside a triangle is to alert the user to the presence high voltage within the unit's enclosure that may be of sufficient power to constitute a risk of electrical shock to persons. Caution: to prevent the risk of electric shock, do not attempt to open the unit. No user-serviceable parts inside. Refer all servicing to qualified service personnel. The exclamation mark inside a triangle is intended to alert the user to the presence of important operating and maintenance instructions in the literature accompanying the appliance. Please read and pay attention to all laser safety warning sticker labels on the unit.

Select the installation location of your unit carefully. Avoid placing it in direct sunlight or locations subject to vibration and excessive dust. Do not use the unit where there are extremes in temperature (below 41°F / 5°C or exceeding 95°F / 35°C).

Unpacking and safety Please unpack your new product carefully. Your new product should reach you in perfect condition. Please check that no damage has occurred during transit. If any damage is found, do not operate your unit. Please contact the retailer you purchased it from immediately. If there is any damage to the mains cable do not use the device. Always disconnect the unit from the mains supply when carrying out any cleaning of the unit.

Manufacturer declarations



In compliance with the following requirements: **RoHS Directive (2002/95/EU)** and **WEEE Directive (2002/96/EU)**.
If this product is ever no longer functional please take it to a recycling plant for environmentally friendly disposal.

CE declaration of conformity

R&TTE Directive (1999/5/EU), EMC Directive (2004/108/EU), Low Voltage Directive (2006/95/EU).

The declarations are available on application from certification@lambapl.com

Before putting the devices into operation, please observe the respective country-specific regulations.

AC power

The unit is supplied with a power plug appropriate to its voltage. Should any other connections be required they must be carried out with the following configuration:

Cable (EU)	Cable (US)	Pin	International
Brown	Black	Live	L
Light blue	White	Neutral	N
Yellow/green	Green	Earth	

DMX-512 connection

If you are using a standard DMX controller, you can connect the DMX output of the controller directly to the DMX input of the first unit in a DMX chain. If you wish to connect a DMX controller with other XLR outputs you will need to use adapter cables.

DMX OUT

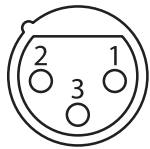

XLR female

DMX IN

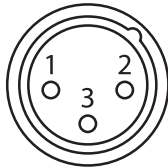

XLR male

1 = ground 2 = minus signal (-) 3 = plus signal (+)

Connect the DMX output of the first unit in a DMX chain with the DMX input of the next unit in the chain. Always connect the the output of one unit with the input of the next unit until all units are connected. If you use a controller with 5 pin DMX connection you will need to use a 5 pin to 3 pin adapter.

Overhead rigging

Important - the installation must be carried out by qualified service personal only. Improper installation can result in serious injuries and /or damage to property. Overhead rigging required extensive experience. Working load limits should be respected, certified installation materials should be used, the installed unit should be inspected regularly for safety.

- Make sure the area below the installation place is free from unwanted persons during rigging, de-rigging and servicing.
- Locate the unit in a well ventilated spot, far away from any flammable materials and/or liquids. The fixture must be fixed **at least 50cm** from surrounding walls
- The device should be installed out of reach of people and outside of areas where persons may walk by or be seated.
- Before rigging make sure that the installation area can hold minimum point load of 10 times the device's weight.
- The device should be well fixed; a free swinging mounting is dangerous.
- Do not cover any ventilation opening as this may result in overheating

Before first time use, the unit should be inspected for safety. Inspection the unit regularly every year.

What is included in the package

- 1 x Kam Power Partybar WFS (including 4 x par cans and T-Bar controller)
- 1 x lighting stand
- 1 x wireless footswitch controller
- 1 x IEC power cable
- 1 x gig bag for main unit
- 1 x instruction manual
- 2 x floor mount/dual connection mounts
- 3 x mounting bolts
- 2 x rubber mounting washers

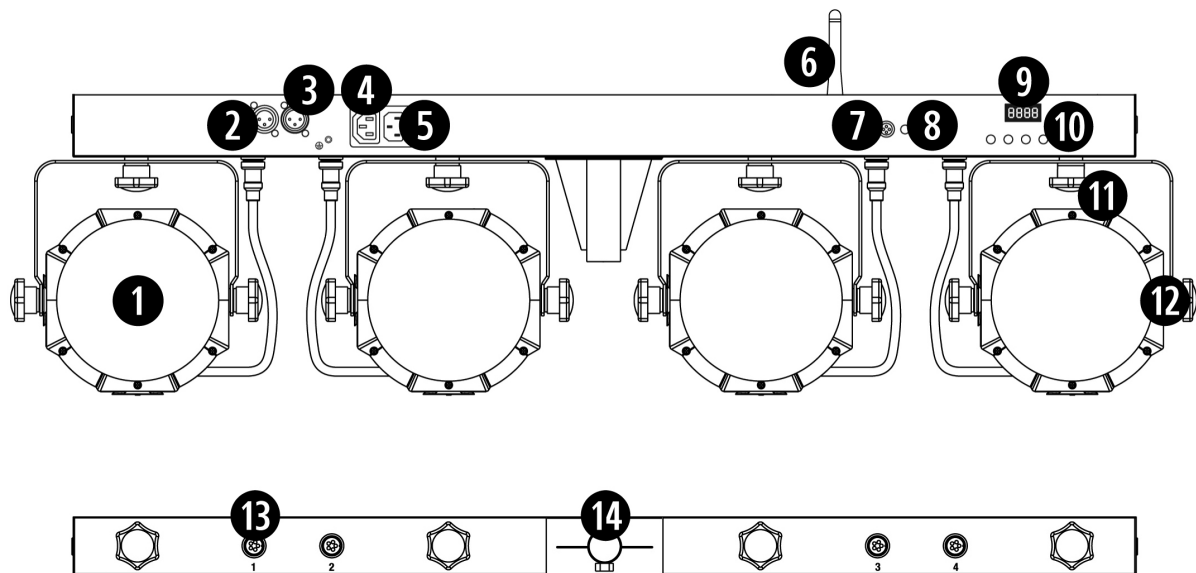

Key to product diagram

1. Par can lighting fixtures
2. DMX output - 3 pin female XLR socket for DMX communication.
3. DMX input - 3 pin male XLR socket for DMX communication.
4. Mains power input IEC socket. Connect the supplied IEC cable to the input and the mains power.
5. Mains power output socket. Insert an IEC connection cable between this socket and a connected unit's power input socket.
6. Retractable aerial - used to communicate with the wireless footswitch (WFS).
7. Microphone - used to monitor the music input during Sound-to-Light mode.
8. Sensitivity - used to adjust the mic's input sensitivity during Sound-to-Light mode.
9. LED display - shows the various menus and the selected functions (see below table).
10. Function buttons x 4 – used to select the different menu items:
 Menu button - choose the function you wish to adjust.
 Up button - used to go up in the menu and to increase the values shown on the display.
 Down button - used to go back in the menu and to lower the values shown on the display.
 Enter button - used to confirm your choice.
11. LED par can connection brackets - used to adjust the panning angle of the par cans.
12. Tilt adjustment brackets - used to adjust the tilt position the par cans.
13. Par can connection sockets - sends the controller signal via the cable to the par cans.
14. Stand insert socket.

Operation

The unit has five working modes:

- Auto mode - built in programs not controlled by the wireless footswitch
- Sound mode - automatic built-in programs - activated via Sound-to-Light
- Manual mode - manual colour mix
- DMX512 mode - DMX512 control via a controller
- Master/Slave mode - unit is controlled by (or controls) other unit(s) in a master/slave chain

Wireless footswitch

Ensure that a working battery is inserted into the underside compartment of the footswitch before operation. Wireless footswitch operation is turned off during DMX and Master/Slave mode.

Pedal	Function
Auto	Press to activate the auto program controls. When working, all the lights will begin in auto mode.
Sound	Press to activate the sound program controls. When working, all the lights will begin in sound mode.
Colour	Press to activate the colour controls. R-G-RG-B-RB-GB-RGB.
Blackout	Press and the unit will go into standby mode and turn all the lights off.

Rear panel Function Setting LED display

Use a combination of the four function setting buttons to set the unit to your desired working mode.

To select any of the menu options, press the MENU button to select the mode required.

Once you have made a selection then press ENTER to confirm.

Use the UP and DOWN buttons to choose the desired menu option.

FUNCTION SETTING



LED Display		Function
R u t	RP0 1-AP 17	Standard Auto programs
	S.0 1-5.99	Effect speed adjustment - 01 is the slowest / 99 is the fastest
S o u	SP0 1-SP 12	Sound-to-Light programs
C o L	CoLo	Manual colour adjustment
	r/G/b***	LED colour setting
	S.00-5.99	Flash light speed adjustment - S.00 = all on / S.99 is the fastest
S y n	Sy-A	Synchronous Auto mode
	Sy-n	Synchronous Sound-to-Light mode
d n H	03/04/20Ch	DMX channel selection
	d***	Channel address setting
S L A	S00 1-S255	Slave mode address setting
S y S	n-En	Sets the Master for synchronous mode (under AUTO/SOUND/COLOR Mode)
	W-En	Wireless footswitch mode
	tEst	On-board testing program
	rEst	Restores the factory setup

MENU button	UP/DOWN buttons	ENTER button	UP/DOWN buttons	ENTER button
Built-in Auto programs AUE	AP01-AP17 Standard Auto shows	Press ENTER to confirm your choice and move on to the speed adjustments.	S.01-S.99 Use the up and down buttons to adjust the effect speed. 01 is the slowest 99 is the fastest.	Press ENTER to confirm your choice.
Built-in Sound programs SOU	SP01-SP12 Auto Sound shows	Press ENTER to confirm your choice. Use the Sensitivity knob on the rear of the unit to adjust how much the effects 'react' to any audio sources/music.		
COLO colour setting COL	R.000-R.255 G.000-G.255 B.000-B.255	Press ENTER to confirm your choice and move on to the speed adjustments.	S.01-S.99 Use the up and down buttons to adjust the flashing/strobe speed. S.00 is all on S.99 is the fastest.	Press ENTER to confirm your choice.
DMX mode dFH	03 / 04 / 20 CH	Press ENTER to confirm your choice of DMX channels	Use the up and down buttons to set the DMX address - d.001-d.XXX	Press ENTER to confirm your choice.
SLAVE mode SLR	When selecting SLAVE mode, this unit will follow the Master unit's built-in program when linked via a DMX cable.	Press ENTER to confirm your choice and move on to the next step.	Use the up and down buttons to set the address - s.001-s.255	Press ENTER to confirm your choice.
System settings SYS	M-En: Master mode	Press ENTER to confirm your choice and move on to the next step.	ON: turn on Master mode OFF: turn off Master mode	Press ENTER to confirm your choice.
	W-En: Wireless footswitch mode	Press ENTER to confirm your choice and move on to the next step.	ON: turn on wireless footswitch mode OFF: turn off wireless footswitch mode	Press ENTER to confirm your choice.
	TEST: Testing mode	Press ENTER to restart the unit		
	REST: Restore the factory setup	Press ENTER to restart the unit		

3 channel DMX mode

Channel	Function	Value	Function
Channel 1		000-009	Blackout
		010-127	Standard Auto mode
		128-255	Flashing Auto mode
Channel 2	Auto shows	000-014	Standard Auto show 1
		015-029	Standard Auto show 2
		030-044	Standard Auto show 3
		045-059	Standard Auto show 4
		060-074	Standard Auto show 5
		075-089	Standard Auto show 6
		090-104	Standard Auto show 7
		105-119	Standard Auto show 8
		120-134	Standard Auto show 9
		135-149	Standard Auto show 10
		150-164	Standard Auto show 11
		165-179	Standard Auto show 12
		180-194	Standard Auto show 13
		195-209	Standard Auto show 14
		210-224	Standard Auto show 15
		225-239	Standard Auto show 16
		240-255	Standard Auto show 17
	Sound-to-Light Auto shows	000-019	Sound-to-Light show 1
		020-039	Sound-to-Light show 2
		040-059	Sound-to-Light show 3
		060-079	Sound-to-Light show 4
		080-099	Sound-to-Light show 5
		100-119	Sound-to-Light show 6
		120-139	Sound-to-Light show 7
		140-159	Sound-to-Light show 8
		160-179	Sound-to-Light show 9
		180-199	Sound-to-Light show 10
		200-219	Sound-to-Light show 11
		220-255	Sound-to-Light show 12
Channel 3		000-255	Program speed setting

4 channel DMX mode

Channel	Value	Description
1	000-255	Red dimmer
2	000-255	Green dimmer
3	000-255	Blue dimmer
4	000-191	RGB overall dimmer
	192-200	Sound-to-Light flashing
	201-249	Flashing speed
	250-255	All on

20 channel DMX mode

Channel	Value	Description
1	000-255	Par can 1 red dimmer
2	000-255	Par can 1 green dimmer
3	000-255	Par can 1 blue dimmer
4	000-255	Par can 1 RGB overall dimmer
5	000-255	Par can 1 flashing speed
6	000-255	Par can 2 red dimmer
7	000-255	Par can 2 green dimmer
8	000-255	Par can 2 blue dimmer
9	000-255	Par can 2 RGB overall dimmer
10	000-255	Par can 2 flashing speed
11	000-255	Par can 3 red dimmer
12	000-255	Par can 3 green dimmer
13	000-255	Par can 3 blue dimmer
14	000-255	Par can 3 RGB overall dimmer
15	000-255	Par can 3 flashing speed
16	000-255	Par can 4 red dimmer
17	000-255	Par can 4 green dimmer
18	000-255	Par can 4 blue dimmer
19	000-255	Par can 4 RGB overall dimmer
20	000-255	Par can 4 flashing speed

Technical specifications

	Kam Power Partybar WFS
Light source / power	4 x 3-in-1 9w RGB LED
Colours	Red 620nm / Green 520nm / Blue 462nm
Control modes	DMX512 / Auto / Sound-to-Light / Master/Slave / Manual
DMX512 channels	3 / 4 / 20
DMX512 connections	3 pin XLR input and output
Control setting	4 buttons plus function setting LED display
Operating temperature	20~40°
Mains power	AC 100-240V 50/60Hz
Mains connection	IEC mains input and output / link
Maximum mains linking	20 units@240V / 10 units@110V
Fuse	T1.6A / 250V
Controller / par can dimensions	1032 x 71 x 235mm (WxDxH)
Footswitch dimensions	420 x 140 x 105mm (WxDxH)
Stand height	1500 to 2500mm
Nett weight	10.2Kg