

## Operation

- With levels turned down, connect a 6.3mm jack lead from the receiver to the P.A. system or mixer and extend the antenna vertical to the receiver unit.
- On the handheld transmitter, with the POWER switch off, unscrew the battery cover and connect a good 9V (PP3) battery to the contacts, taking note that the “+” and “-” connections are correct
- With the VOLUME control turned fully down (anticlockwise), connect the DC adapter to the receiver unit and then into the mains outlet, making sure that the adapter and lead are in good condition.
- Switch on the POWER on the handheld transmitter and check that the RF LED is illuminated on the receiver. Switch off the MUTE and speak loudly into the microphone, checking that the AUDIO PEAK LED on the receiver flashes with the loudest sounds
- Turn up the level on the P.A. system or mixer and then turn up the VOLUME control (clockwise) on the receiver. The microphone should now be heard through the P.A. system or mixer
- After use, turn down the level on the P.A. system or mixer and then turn down the VOLUME on the receiver, MUTE the transmitter and switch off POWER
- Disconnect the receiver from the P.A. system and then unplug from the mains
- If not used for a long period of time, remove the battery from the transmitter

## Specifications

Power supply - Receiver	9-15Vdc (adapter supplied) 200mA
Power supply - Transmitter	9Vdc batter (PP3 type, supplied)
Carrier frequency	174.5MHz
Max deviation	±25kHz
Dynamic range	>90dB
THD	<0.5%
Frequency response	40Hz-15kHz ±3dB
Audio output	400mV
Signal to noise ratio	>90dB
Channel rejection	>80dB
Receiver sensitivity	10dBuV
Max continuous battery life	10 hours
Dimensions - Receiver / Transmitter	150 x 110 x 35mm / 250 x 50mmØ
Weight - Receiver / Transmitter	190g / 280g



VH45B

## Wireless Microphone System

171.801



# USER MANUAL

CE1622

© QTX Sound 2010

Thank you for your purchase of the VH45B wireless microphone system. Please read the following instructions carefully before using this product to ensure best results and to avoid damage through misuse.

Note – no user serviceable parts inside, refer all servicing to a qualified technician.

### Safety

- Connect the D.C. adapter to the wireless receiver and ensure the correct mains voltage and that the D.C. adapter and lead is intact before plugging into the mains outlet
- Ensure that the handheld transmitter has a 9V battery (PP3) installed which is in good condition with adequate charge (alkaline type is recommended)
- Avoid contact with moisture for any of the system components and keep all parts clear of dust and foreign objects
- Keep all components away from heat sources (amplifiers, heaters, radiators etc.) and out of direct sunlight
- Remove battery from the handheld unit and power adapter from receiver when not being used for long periods of time.
- Position the receiver on a stable surface and take care when placing the transmitter down so that it doesn't roll and fall off the surface.
- Clean transmitter and receiver periodically with a dry or slightly damp cloth. Do not use solvents or abrasives on the plastic and metal parts.
- Avoid impact or pressure on casing of all components

### Features

- Stable quartz tuned VHF carrier frequency
- Multi-level high and mid frequency narrowband filtering to eliminate interference.
- Individual Mute switch on handheld transmitter to allow muting prior to switching on or off, avoiding clicks and pops
- LED indicators for Power, RF, Audio Peak, Low battery
- Audio companding circuitry for accurate dynamics without audible distortion
- Auto-muting circuitry to eliminate noise when transmitter is not detected
- Neat and compact design

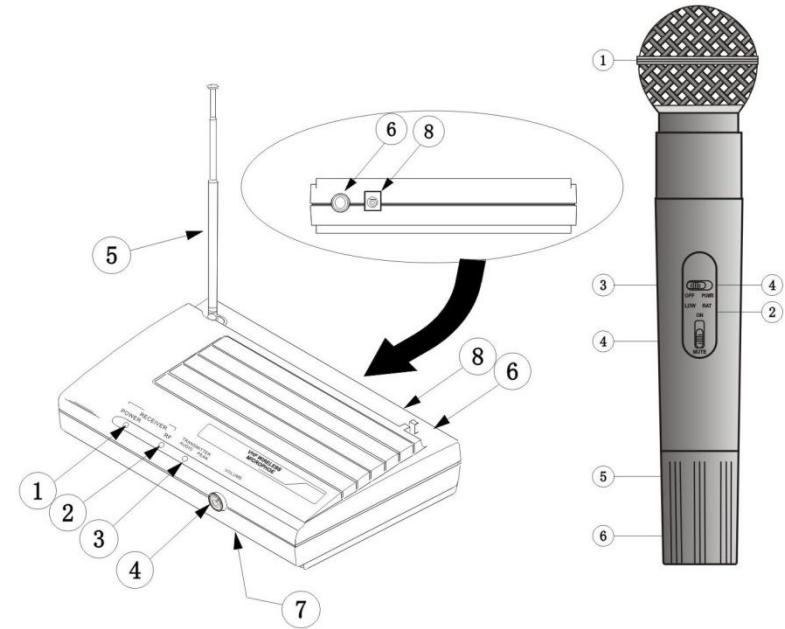

### Receiver

1. POWER LED – illuminated when power to receiver is on
2. RF LED – illuminated when receiver detects RF carrier signal
3. AUDIO PEAK LED – illuminates to indicate audio reaching peak level
4. VOLUME – rotate clockwise to increase output level
5. ANTENNA – fold-away VHF telescopic aerial
6. OUTPUT – 6.3mm jack unbalanced audio output
7. CASE – sturdy plastic receiver housing
8. DC INPUT – 2.1mm power connector for 9-15Vdc input

### Transmitter

1. GRILLE – windshield with integral pop filter
2. LOW BATT LED – illuminates when battery charge is low
3. POWER LED – illuminates to show battery power is on
4. POWER & MUTE – switches to activate battery and mute output
5. GAIN – screw adjustment inside battery compartment to adjust mic gain
6. COVER – screw-on cover for battery compartment