

# **RD** *Power Dynamics* *Professional Audio*

- 171.142 PDM-S803 Stage Mixer 8Ch DSP/MP3
- 171.144 PDM-S1203 Stage Mixer 12Ch DSP/MP3
- 171.147 PDM-S1603 Stage Mixer 16Ch DSP/MP3
- 171.151 PDM-S1203A Ampl. Mixer 12ch DSP/MP3



## **USER MANUAL**

## Important safety instructions



### Caution !

To reduce the risk of electric shock, do not remove the top cover (or the rear section). No user serviceable parts inside. Refer servicing to qualified personnel

### Caution !

To reduce the risk of fire or electric shock, do not expose this appliance to rain and moisture. The apparatus shall not be exposed to dripping or splashing liquids and no objects filled with liquids, such as vases, shall be placed on the apparatus.



This symbol, wherever it appears, alerts you to important operating and maintenance instructions in the accompanying literature. Please read the manual.



This symbol, wherever it appears, alerts you to the presence of uninsulated dangerous voltage inside the enclosure - voltage that may be sufficient to constitute a risk of shock.

### Caution !

- [1]. Keep these instructions.
- [2]. Heed all warnings.
- [3]. Follow all instructions.
- [4]. Follow all instructions.
- [5]. Do not use this apparatus near water
- [6]. Clean only with dry cloth.
- [7]. Do not block any ventilation openings. Install in accordance with the manufacturer's instructions.
- [8]. Do not install near any heat sources such as radiators, heat registers, stoves, or other apparatus (including amplifiers) that produce heat.
- [9]. Do not defeat the safety purpose of the polarized or grounding-type plug. A polarized plug has two blades with one wider than the other. A grounding-type plug has two blades and a third grounding prong. The wide blade or the third prong are provided for your safety. If the provided plug does not fit into your outlet, consult an electrician for replacement of the obsolete outlet.
- [10]. Place the power cord so that it is protected from being walked on and sharp edges. Be sure that the power cord is protected particularly at plugs, convenience receptacles and the point where it exits from the apparatus
- [11]. The apparatus shall be connected to a MAINS socket outlet with a protective earthing connection.

- [12]. Where the MAINS plug or an appliance coupler is used as the disconnect device, the disconnect device shall remain readily operable.



- [13]. Only use attachments/accessories specified by the manufacturer.
- [14]. Use only with the cart, stand, tripod, bracket, or table specified by the manufacturer, or sold with the apparatus. When a cart is used, use caution when moving the cart / apparatus combination to avoid injury from tip-over.
- [15]. Unplug this apparatus during lightning storms or when unused for long periods of time.
- [16]. Refer all servicing to qualified service personnel. Servicing is required when the apparatus has been damaged in any way, such as power supply cord or plug is damaged, liquid has been spilled or objects have fallen into the apparatus, the apparatus has been exposed to rain or moisture, does not operate normally, or has been dropped.

## Before you get started Shipment

Your mixing console was carefully packed in the factory to guarantee safe transport. Nevertheless, we recommend that you carefully examine the packaging and its contents for any signs of physical damage, which may have occurred during transit.

- ☞ If the unit is damaged, please do NOT return it to us, but notify your dealer and the shipping company immediately, otherwise claims for damage or replacement may not be granted.

## Initial operation

Be sure that there is enough space around the unit for cooling purposes and to avoid over-heating please do not place your mixing console on high-temperature devices such as radiators or power amps. The console is connected to the mains via the supplied cable. The console meets the required safety standards. Blown fuses must only be replaced by fuses of the same type and rating.

- ☞ Please note that all units must be properly grounded. For your own safety, you should never remove any ground connectors from electrical devices or power cables, or render them inoperative.
- ☞ Please ensure that only qualified people install and operate the mixing console. During installation and operation, the user must have sufficient electrical contact to earth, otherwise electrostatic discharges might affect the operation of the unit.

# Introduction

Please read through this manual carefully before beginning use, so that you will be able to take full advantage of this mixer's superlative features.

## Contents

Introduction.....	1
Contents.....	2
Balanced, Unbalanced-What's the Difference?.....	3
Signal Levels and the Decibel.....	3
To EQ or Not to EQ.....	4
Ambience.....	5
The Modulation Effects.....	5
Compression.....	5
Setup.....	6
Functional specification.....	7-10
Installation.....	11
Specifications.....	12
Troubleshooting.....	13

You've got yourself a mixer and now you're ready to use it.

Just plug everything in, twiddle the controls, and away you go ... right?

Well, if you've done this before you won't have any problems, but if this is the first time you've ever used a mixer you might want to read through this little tutorial and pick up a few basics that will help you get better performance and make better mixes.

## Balanced, Unbalanced—What's the Difference?

In a word: "noise." The whole point of balanced lines is noise rejection, and it's something they're very good at. Any length of wire will act as an antenna to pick up the random electromagnetic radiation we're constantly surrounded by: radio and TV signals as well as spurious electromagnetic noise generated by power lines, motors, electric appliances, computer monitors, and a variety of other sources. The longer the wire, the more noise it is likely to pick up. That's why balanced lines are the best choice for long cable runs. If your "studio" is basically confined to your desktop and all connections are no more than a meter or two in length, then unbalanced lines are fine—unless you're surrounded by extremely high levels of electromagnetic noise. Another place balanced lines are almost always used is in microphone cables. The reason for this is that the output signal from most microphones is very small, so even a tiny amount of noise will be relatively large, and will be amplified to an alarming degree in the mixer's high-gain head amplifier.

### Balanced noise cancellation

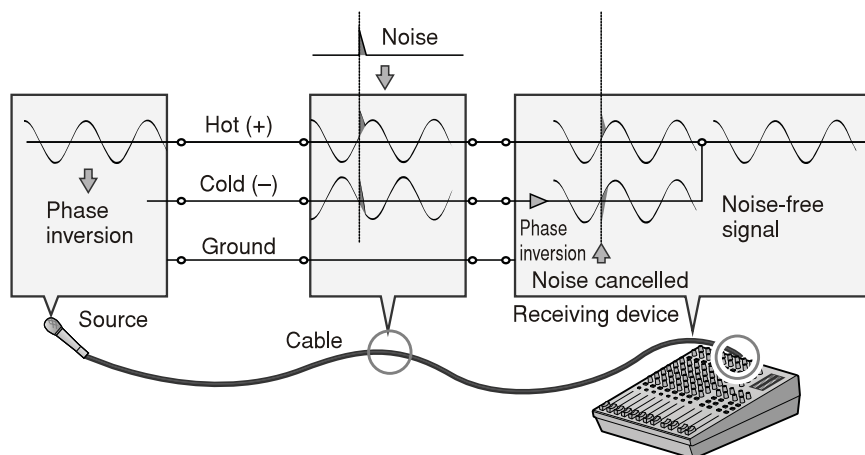

### To summarize

<b>Microphones</b>	Use balanced lines.
<b>Short line-level runs</b>	Unbalanced lines are fine if you're in a relatively noise-free environment.
<b>Long line-level runs</b>	The ambient electromagnetic noise level will be the ultimate deciding factor, but balanced is best.

## Signal Levels and the Decibel

Let's take a look at one of the most commonly used units in audio: the decibel (dB). If the smallest sound that can be heard by the human ear is given an arbitrary value of 1, then the loudest sound that can be heard is approximately 1,000,000 (one million) times louder. That's too many digits to deal with for practical calculations, and so the more appropriate "decibel" (dB) unit was created for sound-related measurements. In this system the difference between the softest and loudest sounds that can be heard is 120 dB. This is a non-linear scale, and a difference of 3 dB actually results in a doubling or halving of the loudness.

You might encounter a number of different varieties of the dB: dBu, dBV, dBm and others, but the dBu is the basic decibel unit. In the case of dBu, "0 dBu" is specified as a signal level of 0.775 volts. For example, if a microphone's output level is -40 dBu (0.00775 V), then to raise that level to 0 dBu (0.775 V) in the mixer's preamp stage requires that the signal be amplified by 100 times.

A mixer may be required to handle signals at a wide range of levels, and it is necessary match input and output levels as closely as possible. In most cases the "nominal" level for a mixer's input and outputs is marked on the panel or listed in the owner's manual.

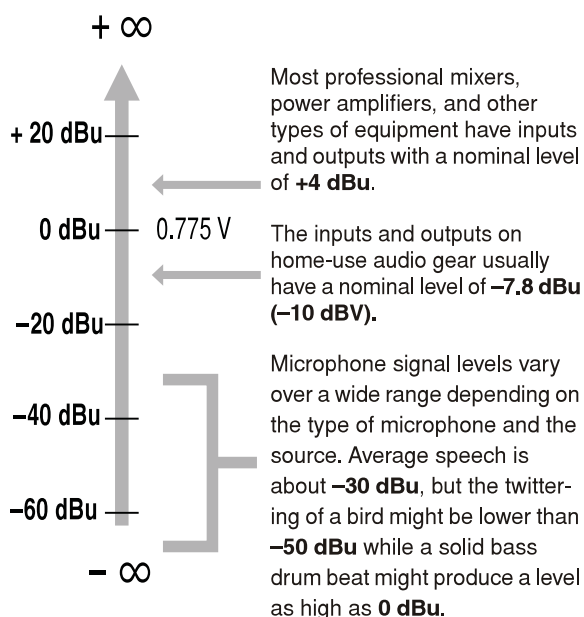

# To EQ or Not to EQ

In general: less is better. There are many situations in which you'll need to cut certain frequency ranges, but use boost sparingly, and with caution. Proper use of EQ can eliminate interference between instruments in a mix and give the overall sound better definition. Bad EQ—and most commonly bad boost—just sounds terrible.

## Cut for a Cleaner Mix

For example: cymbals have a lot of energy in the mid and low frequency ranges that you don't really perceive as musical sound, but which can interfere with the clarity of other instruments in these ranges. You can basically turn the low EQ on cymbal channels all the way down without changing the way they sound in the mix. You'll hear the difference, however, in the way the mix sounds more "spacious," and instruments in the lower ranges will have better definition. Surprisingly enough, piano also has an incredibly powerful low end that can benefit from a bit of low-frequency roll-off to let other instruments—notably drums and bass—do their jobs more effectively. Naturally you won't want to do this if the piano is playing solo.

The reverse applies to kick drums and bass guitars: you can often roll off the high end to create more space in the mix without compromising the character of the instruments. You'll have to use your ears, though, because each instrument is different and sometimes you'll want the "snap" of a bass guitar, for example, to come through.

The fundamental and harmonic frequency ranges of some musical instruments.

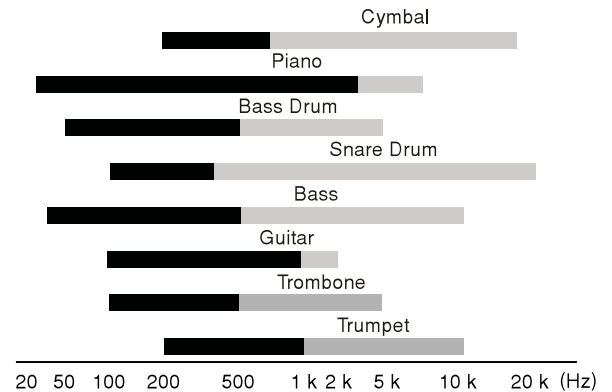

- Fundamental: The frequency that determines the basic musical pitch.
- Harmonics: Multiples of the fundamental frequency that play a role in determining the timbre of the instrument.

## Some Frequency Facts

The lowest and highest frequencies than can be heard by the human ear are generally considered to be around 20 Hz and 20,000 Hz, respectively. Average conversation occurs in the range from about 300 Hz to about 3,000 Hz. The frequency of a standard pitchfork used to tune guitars and other instruments is 440 Hz (this corresponds to the "A3" key on a piano tuned to concert pitch). Double this frequency to 880 Hz and you have a pitch one octave higher (i.e. "A4" on the piano keyboard). In the same way you can halve the frequency to 220 Hz to produce "A2" an octave lower.

## Boost with Caution

If you're trying to create special or unusual effects, go ahead and boost away as much as you like. But if you're just trying to achieve a good-sounding mix, boost only in very small increments. A tiny boost in the midrange can give vocals more presence, or a touch of high boost can give certain instruments more "air." Listen, and if things don't sound clear and clean try using cut to remove frequencies that are cluttering up the mix rather than trying to boost the mix into clarity.

One of the biggest problems with too much boost is that it adds gain to the signal, increasing noise and potentially overloading the subsequent circuitry.

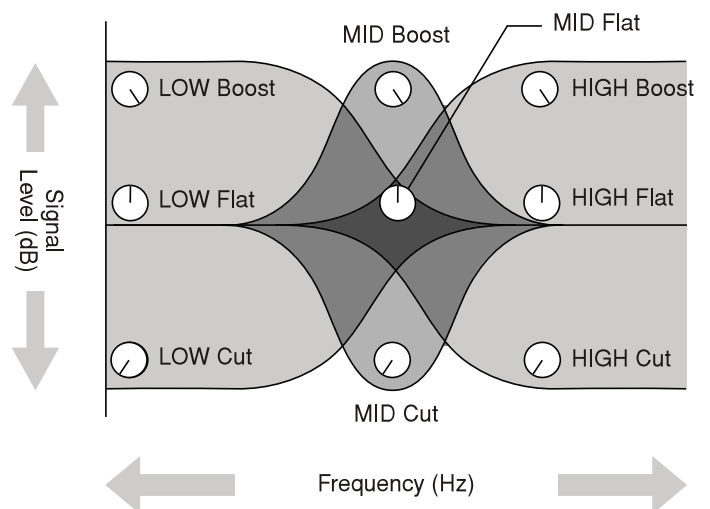

## Ambience

Your mixes can be further refined by adding ambience effects such as reverb or delay. The GS-12FX's internal effects can be used to add reverb or delay to individual channels in the same way as external effects processors. (Refer to page 15).

### **Reverb and Delay Time**

The optimum reverb time for a piece of music will depend on the music's tempo and density, but as a general rule longer reverb times are good for ballads, while shorter reverb times are more suited to up-tempo tunes. Delay times can be adjusted to create a wide variety of "grooves". When adding delay to a vocal, for example, try setting the delay time to dotted eighth notes corresponding to the tune's tempo.

### **Reverb Tone**

Different reverb programs will have different "reverb tone" due to differences in the reverb time of the high or low frequencies. Too much reverb, particularly in the high frequencies, can result in unnatural sound and interfere with the high frequencies in other parts of the mix. It's always a good idea to choose a reverb program that gives you the depth you want without detracting from the clarity of the mix.

### **Reverb Level**

It's amazing how quickly your ears can lose perspective and fool you into believing that a totally washed-out mix sounds perfectly fine. To avoid falling into this trap start with reverb level all the way down, then gradually bring the reverb into the mix until you can just hear the difference. Any more than this normally becomes a "special effect."

## The Modulation Effects:

### **Phasing, Chorus, and Flanging**

All of these effects work on basically the same principle: a portion of the audio signal is "time-shifted" and then mixed back with the direct signal. The amount of time shift is controlled, or "modulated", by an LFO (Low-frequency Oscillator).

For phasing effects the shift is very small. The phase difference between the modulated and direct signals causes cancellation at some frequencies and reinforces the signal at others and this causes the shimmering sound we hear.

For chorus and flanging the signal is delayed by several milliseconds, with the delay time modulated by an LFO, and recombined with the direct signal. In addition to the phasing effect described above, the delay modulation causes a perceived pitch shift which, when mixed with the direct signal, results in a harmonically rich swirling or swishing sound.

The difference between chorus and flanging effects is primarily in the amount of delay time and feedback used—flanging uses longer delay times than chorus, whereas chorus generally uses a more complex delay structure. Chorus is most often used to thicken the sound of an instrument, while flanging is usually used as an outright "special effect" to produce otherworldly sonic swoops.

## Compression

One form of compression known as "limiting" can, when properly used, produce a smooth, unified sound with no excessive peaks or distortion. A common example of the use of compression is to "tame" a vocal that has a wide dynamic range in order to tighten up the mix. With the right amount of compression you'll be able to clearly hear whispered passages while passionate shouts are still well balanced in the mix. Compression can also be valuable on bass guitar. Too much compression can be a cause of feedback, however, so use it sparingly.

Most compressors require several critical parameters to be set properly to achieve the desired sound. The MG compressor makes achieving great sound much easier: all you need to do is set a single "compression" control and all of the pertinent parameters are automatically adjusted for you.

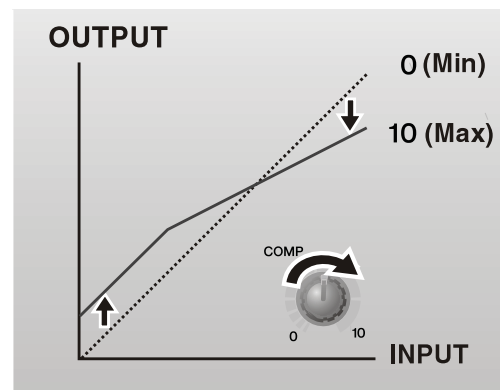

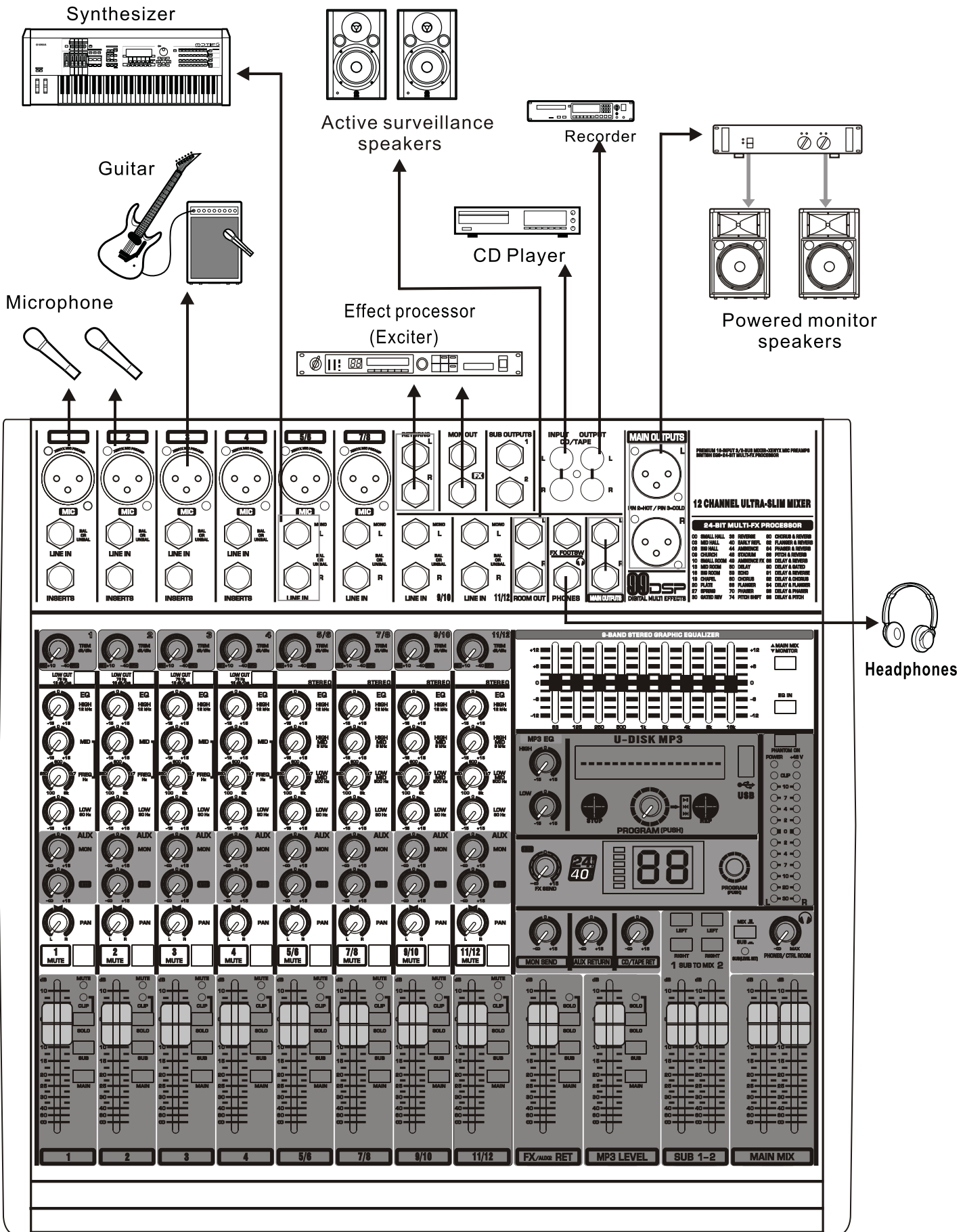

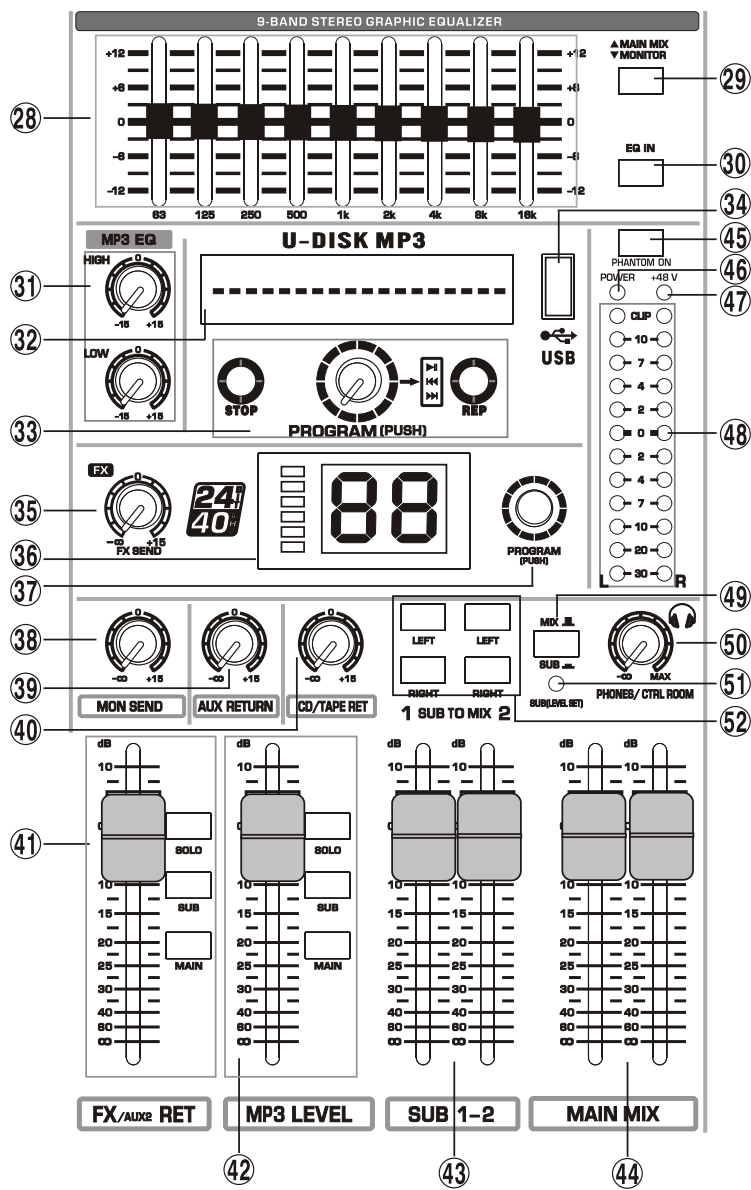
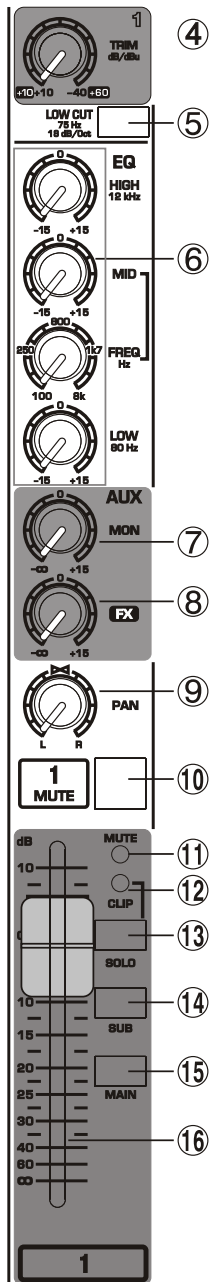
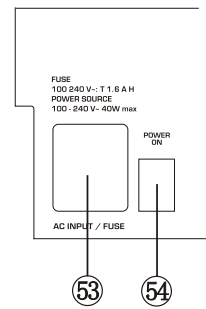
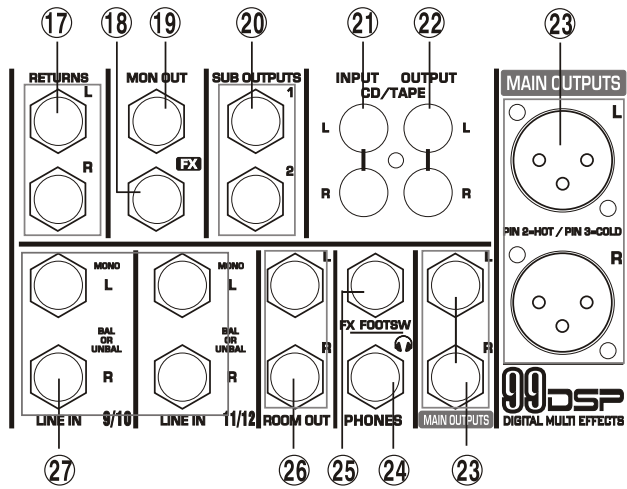
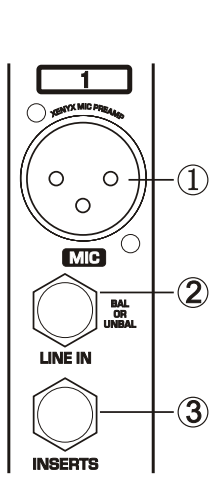



## **1. MIC Input jacks**

These are balanced XLR-type microphone input jacks. (1:Ground; 2: Hot; 3: Cold)

## **2. LINE Input Jacks (monaural channels)**

These are balanced TRS phone-jack line inputs. (T: Hot; R: Cold; S: Ground). You can connect either balanced or unbalanced phone plugs to these jacks.

## **3. INSERT Jacks**

These jacks can be used to insert an external signal-processing device between the equalizer and fader of the corresponding monaural input channel. The INSERT jacks are ideal for connecting devices such as graphic equalizers, compressors, or noise filters into the corresponding channels.

## **4. TRIM Control**

Adjusts the input signal level. To get the best balance between the S/N ratio and the dynamic range, adjust the gain so that the PEAK indicator lights only occasionally and briefly on the highest input transients. The -60 to +10 scale is the MIC input adjustment range. The 40 to +10 scale is the LINE input adjustment range.

## **5. LOW OUT SWITCH**

This switch toggles the HPF on or off. To turn the HPF on, The HPF cuts frequencies below 75 Hz.

## **6. Equalizer (HIGH, MID and LOW)**

This three-band equalizer adjusts the channel's high, mid and low frequency bands. Setting the knob to the "0" position produces a flat response in the corresponding band. Turning the knob to the right boosts the corresponding frequency band, while turning to the left attenuates the band.

## **7. AUX Control**

Monitor and effects busses (AUX sends) source their signals via a control from one or more channels and sum these signals to a so-called bus. This bus signal is sent to an aux send connector (for monitoring applications: MON OUT) and then routed, for example, to an active monitor speaker or external effects device. In the latter case, the effects return can then be brought back into the console via the aux return connectors. All monitor and effects busses are mono, are tapped into post EQ and offer amplification of up to +15 dB.

## **8. FX Control**

The aux send marked FX offers a direct route to the built-in effects processor and is therefore post-fader and post-mute.

## **9. PAN Control**

The PAN control determines the position of the channel signal within the stereo image. When working with subgroups, you can use the PAN control to assign the signal to just one output, which gives you additional flexibility in recording situations. For example, when routing to subgroups 3 and 4, panning hard left will route the signal to group output 3 only, and panning hard right will route to group output 4 only.

## **10. MUTE Switch**

Turn this switch on to send the signal to the buses. The switch lights orange when on.

## **11. MUTE LED**

The MUTE LED indicates a muted channel.

## **12. CLIP LED**

The PEAK-LED lights up when the input signal is driven too high. If this happens, back off the TRIM control and, if necessary, check the setting of the channel EQ.

## **13. SOLO SWITCH**

The SOLO switch is used to route the channel signal to the solo bus (Solo In Place) or to the PFL bus (Pre Fader Listen). This enables you to listen to a channel signal without affecting the main output signal. The signal you hear is taken either before the pan control (PFL, mono) or after the pan and channel fader (Solo, stereo)

## **14. SUB Switch**

This switch aligns the channel.

## **15. MAIN Switch**

This switch aligns the channel's signal.

## **16. CHANNEL FADER**

Adjusts the level of the channel signal. Use these faders to adjust the balance between the various channels.

## **17. STEREO AUX RETURNS Jacks**

The STEREO AUX RETURN jacks generally serve as the return for the effects mix ( created using the post-fader aux sends ) by connecting the output of an external effects device. If only the left jack is connected, the AUX RETURN is automatically switched to mono.

## **18. AUX SEND1 Jacks**

The AUX SEND jack should be used when hooking up a monitor power amp or active monitor speaker system. The relevant aux path should be set pre-fader.

## **19. MON Jack**

The MON jack carries the master aux mix (from the channel's AUX MON controls).

## **20. SUB1-2 OUT Jacks**

These impedance-balanced\* TRS phone jacks output the ALT3-4 signals. Use these jacks to connect to the input jacks of an multi-track recorder, external mixer, or other such device.

## **21. CD IN JACKS**

These RCA pin jacks input a stereo sound source. Use these jacks when you want to connect a CD player directly to the mixer.

## **22. REC OUT (L, R) Jacks**

These RCA pin jacks can be connected to an external recorder such as an MD recorder in order to record the same signal that is being output via the STEREO OUT jacks.

## **23. MAIN OUT (L, R) Jacks**

These jacks deliver the mixer's stereo output. You use these jacks, for example, to connect to the power amplifier driving your main speakers.

## **24. PHONES Jack**

Connect a pair of headphones to this TRS phone-type output jack.

## **25. FX FOOTSW Jacks**

Connect a standard foot switch to the foot switch jack and use this to switch the effects processor on and off. A light at the bottom of the display indicates whether the effects processor has been muted by the foot switch.

## **26. CONTROL ROOM OUT Jacks**

The control room output is normally connected to the monitoring system in the control room and carries the stereo mix or, when selected, the solo signals.

## **27. STEREO Jacks**

Each stereo channel has two balanced line level inputs on jacks for left and right channels. If only the left jack (marked "L" ) is used, the channel operates in mono. The stereo channels are designed to handle typical line level signals, and depending on model, have a level switch (+4 dBu or -10 dBV ) and/or a line GAIN control. Both jack inputs will also accept unbalanced connectors.

## **28. 9-BAND STEREO GRAPHIC EQUALIZER**

The graphic stereo equalizer allows you to tailor the sound to the room acoustics.

## **29. FBQ FEEDBACK DETECTION SWITCH**

The switch turns on the FBQ Feedback Detection System. It uses the LEDs in the frequency band faders to indicate the critical frequencies. On a per-need basis, lower the frequency range in question somewhat in order to avoid feedback. The graphic stereo equalizer has to be turned on in order to use this function.

## **30. EQ IN SWITCH**

Use this switch to activate the graphic equalizer.

## **31. MP3 PLAY EQ**

The two-band equalizer adjusts the level of the two bands of the Mp3 player.

## **32. MP3 PLAY window**

Show the Mp3 playing time, song name and other play instruction.

## **33. MP3 switch**

STOP: stop play PLAY: play music PREV: last song NEXT: next song REP: single or cycle play

## **PROGRAM Dial**

You can select the Mp3 preset by turning the PROGRAM control. The display flashes with the number of the current preset. To recall the selected preset, press on the button; the flashing stops.

## **34. MP3 player jack**

USB: can be played through U-DISK

### 35. AUX SEND2(FX) Control

The AUX SEND (FX) jack carries the master aux mix (from The channel's FX controls). You can connect this to an external effects device to process the FX bus. The processed signal can then be brought from the effects device back into the STEREO AUX RETURN jacks.

### 36. EFFECTOR LEVEL LIGHT

Show the effect level stronger

### EFFECTOR DISPLAY

Show the kind of effector.

### 37. PROGRAM Dial

You can select the effect preset by turning the PROGRAM control. The display flashes with the number of the current preset. To recall the selected preset, press on the button; the flashing stops. You can also recall the selected preset with the foot switch.

### 38. MON SEND Control

Use this fader can control the MON output jack

### 39. STEREO AUX RETURN1 Control

Adjusts the level at which the signal received at the RETURN jacks (L (MONO) and R) is sent to the STEREO L/R bus.

### 40. CD/TAPE RET Control

Adjusts the level of the signal sent from the CD IN jacks.

### 41. FX SEND Fader

Control effect input signal level & SEND FX jack input.

### 42. MP3 VOL Fader

Change VOL button can be control the VOL of Mp3.

### 43. SUB1-2 FADER

You use the high-precision quality faders to control the output level of the subgroups.

### 44. MAIN MIX FADER

You use the high-precision quality faders to control the output level of the main mix.

### 45. PHANTOM +48 V Switch

This switch toggles phantom power on and off. When the switch is on the mixer supplies +48V phantom power to all channels that have XLR mic input jacks. Turn this switch on

### 46. POWER Indicator

This indicator lights when the mixer's power is ON.

### 47. 48V Indicator

The red "48V LED lights up when phantom power is switched on. Phantom power is required to operate condenser microphones.

### 48. Level Meter

Show the level signal's strong

**NOTE: The "0" segment corresponds to the nominal output level. The PEAK indicator lights red when the output reaches the clipping level..**

### 49. MIX/SUB Switch

This switch assigns the Phones signal to the SUB/MIX bus.

### 50. PHONES/CTRL ROOM ONLY Control

Use this control to adjust the control room output level and the headphones volume.

### 51. PFL indicator

when open the monitor, PEL is lighting.

### 52. SUB TO MAIN Switch

If this switch is on, the mixer sends the signals processed BY the SUB faders onto the stereo bus.

### 53. FUSE HOLDER/IEC MAINS RECEPTACLE

The console is connected to the mains via the cable supplied, which meets the required safety standards. Blown fuses must only be replaced by fuses of the same type and rating. The mains connection is made via a cable with IEC mains connector. An appropriate mains cable is supplied with the equipment.

### 54. POWER Switch

Use the POWER switch to turn on the mixing console. The POWER switch should always be in the "Off" position when you are about to connect your unit to the mains. To disconnect the unit from the mains, pull out the main cord plug. When installing the product, ensure that the plug is easily accessible. If mounting in a rack, ensure that

## INSTALLATION

### Rack mounting

The packaging of your mixing console contains two 19" rack mounts for installation on the side panels of the console.

Before you can attach the rack mounts to the mixing console, you need to remove the screws holding the left and right side panels. Then, use these screws to fasten the two rack mounts, each specifically to one side. With the rack mounts installed, you can mount the mixing console in a commercially available 19" rack. Be sure to allow for proper air flow around the unit, and do not place the mixing console close to radiators or power amps, so as to avoid overheating.

Only use the screws holding the mixing console side panels to fasten the 19" rack mounts.

### Cable connections

You will need a large number of cables for the various connections of the console. The illustrations below show the wiring of these cables. Be sure to use only high-grade cables.

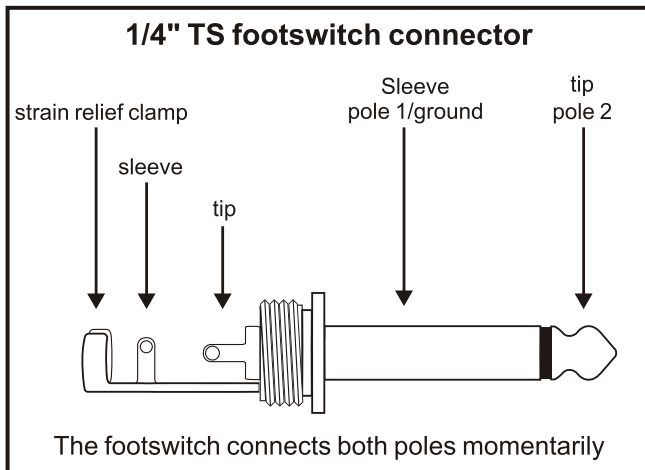

Foot switch connector

### Audio connections

Please use commercial RCA cables to wire the 2-track inputs and outputs. You can, of course, also connect unbalanced devices to the balanced input/outputs. Use either mono plugs, or use stereo plugs to link the ring and shaft (or pins 1 & 3 in the case of XLR connectors).

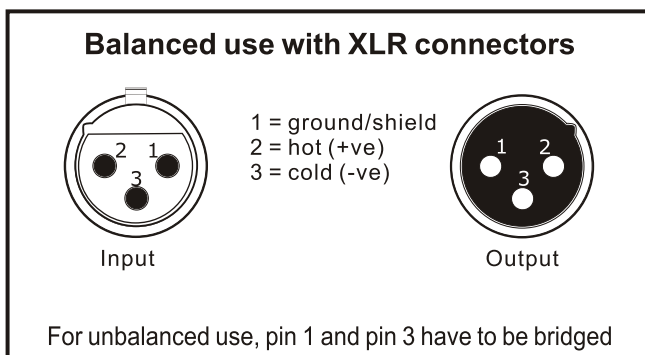

### XLR connections

Caution! You must never use unbalanced XLR connectors (PIN 1 and 3 connected) at the MIC input jacks if you want to use the phantom power supply.

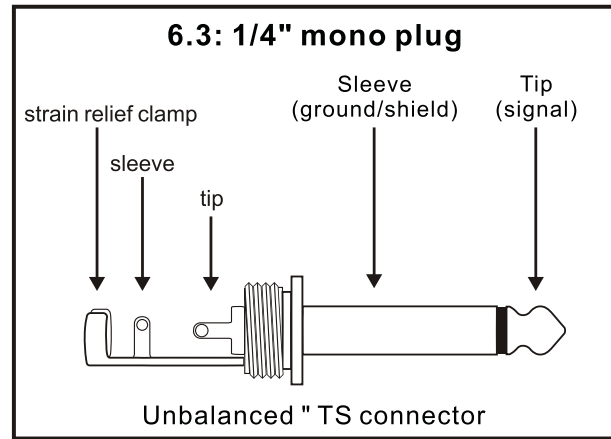

### 6.3: 1/4" mono plug

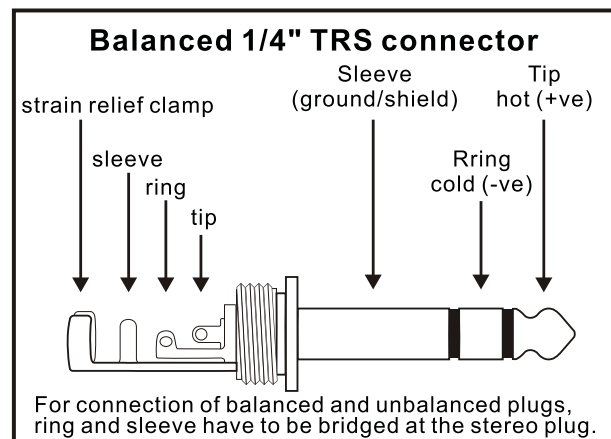

### Balanced 1/4" TRS connector

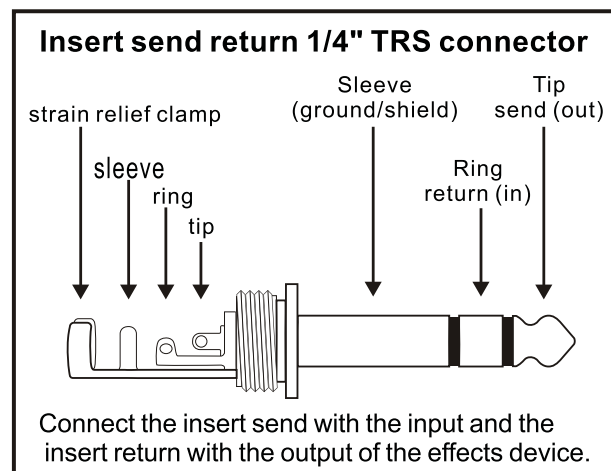

### Insert send/return stereo plug

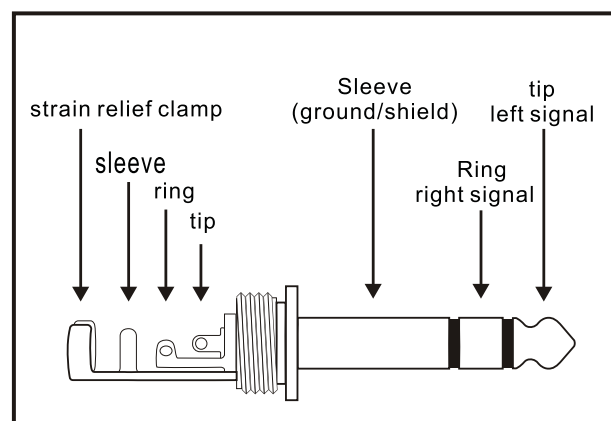

### 1/4" TRS headphones connector

# Specifications

## MICROPHONE INPUTS (XENYX MIC PREAMP)

Type	XLR, electronically balanced, discrete input circuit
<b>Mic E.I.N. (20 Hz - 20 kHz)</b>	
@ 0 $\Omega$ source resistance	-134 dB / 135.7 dB A-weighted
@ 50 $\Omega$ source resistance	-131 dB / 133.3 dB A-weighted
@ 150 $\Omega$ source resistance	-129 dB / 130.5 dB A-weighted
Frequency response	<10 Hz - 150 kHz (-1 dB), <10 Hz - 200 kHz (-3 dB)
Gain range	+10 to +60 dB
Max. input level	+12 dBu @ +10 dB Gain
Impedance	approx. 2.6 k $\Omega$ balanced
Signal-to-noise ratio	110 dB / 112 dB A-weighted (0 dBu In @ +22 dB gain)
Distortion (THD+N)	0.005% / 0.004% A-weighted
<b>Line input</b>	
Type	¼" TRS connector electronically balanced
Impedance	approx. 20 k $\Omega$ balanced 10 k $\Omega$ unbalanced
Gain range	-10 to +40 dB
Max. input level	30 dBu

## FADE-OUT ATTENUATION<sup>1</sup> (CROSSTALK ATTENUATION)

Main fader closed	90 dB
Channel muted	89 dB
Channel fader closed	89 dB

## FREQUENCY RESPONSE

<b>Microphone input to main out</b>	
<10 Hz - 90 kHz	+0 dB / -1 dB
<10 Hz - 160 kHz	+0 dB / -3 dB
<b>Stereo inputs</b>	
Type	¼" TRS connector, electronically balanced
Impedance	approx. 20 k $\Omega$
Max. input level	+22 dBu
<b>EQ mono channels</b>	
Low	80 Hz / $\pm$ 15 dB
Mid	100 Hz - 8 kHz / $\pm$ 15 dB
High	12 kHz / $\pm$ 15 dB
<b>EQ stereo channels</b>	
Low	80 Hz / $\pm$ 15 dB
Low Mid	500 Hz / $\pm$ 15 dB
High Mid	3 kHz / $\pm$ 15 dB
High	12 kHz / $\pm$ 15 dB
<b>Aux sends</b>	
Type	¼" TS connector, unbalanced
Impedance	approx. 120 $\Omega$
Max. output level	+22 dBu

## Stereo aux returns

Type	¼" TRS connector, electronically balanced
Impedance	approx. 20 k $\Omega$ bal. / 10 k $\Omega$ unbal.
Max. input level	+22 dBu

## Main outputs

Type	XLR, electronically balanced and ¼" TRS balanced
1622FX only:	¼" TS connector unbalanced
Impedance	approx. 240 $\Omega$ symm. / 120 $\Omega$ unbalanced
Max. output level	+28 dBu +22 dBu

## Control room outputs

Type	¼" TS connector unbalanced
Impedance	approx. 120 $\Omega$
Max. output level	+22 dBu

## Headphones outputs

Type	¼" TRS connector, unbalanced
Max. output level	+19 dBu / 150 $\Omega$ (+25 dBm)

## DSP

Converter	24-bit Sigma-Delta, 64/128-times oversampling
Sampling rate	40 kHz

## MAIN MIX SYSTEM DATA<sup>2</sup>

### Noise

Main mix @ $-\infty$ Channel fader @ $-\infty$	-101 dB -100 dB
Main mix @ 0 dB, Channel fader @ $-\infty$	-93 dB -96 dB -87 dB
Main mix @ 0 dB, Channel fader @ 0 dB	-81 dB -83 dB -80 dB

### Power supply

Mains voltage	100 to 240 V~, 50/60 Hz
---------------	-------------------------

### Power consumption

CH.6	40W
CH.8	40W
CH.12	50W
CH.16	50W
Fuse	100 - 240 V ~: T 1.6 A H 250 V
Mains connection	Standard IEC receptacle

Measuring conditions:

- 1 kHz rel. to 0 dBu; 20 Hz - 20 kHz; line input; main output; unity gain.
- 20 Hz - 20kHz; measured at main output. Channels 1 - 4 unity gain; EQ flat; all channels on main mix; channels 1/3 as far left as possible, channels 2/4 as far right as possible. Reference = +6 dBu.

## Troubleshooting

<p><b>Power doesn't come on.</b></p>	<ul style="list-style-type: none"> <li>• Is the power line properly plugged into an AC wall outlet?</li> <li>• Are the power line and AC wall outlet connected correctly?</li> </ul>
<p><b>No sound</b></p>	<ul style="list-style-type: none"> <li>• Are microphone, external devices, and speakers connected correctly?</li> <li>• Are the channel GAIN controls, channel fader, STEREO OUT Master fader and GROUP fader set to appropriate levels?</li> <li>• Are the speaker cables connected properly, or are they shorted?</li> <li>• If the above checks do not identify the problem, please contact the service center.</li> </ul>
<p><b>Sound is faint, distorted, or noisy</b></p>	<ul style="list-style-type: none"> <li>• Are the channel GAIN controls, channel fader, STEREO OUT Master fader and GROUP fader set to appropriate levels?</li> <li>• Are two different instruments connected to the XLR-type and phone jacks, or to the phone and RCA pin jacks on one channel? Please connect to only one of these jacks on each channel.</li> <li>• Is the input signal from the connected device set to an appropriate level?</li> <li>• Are you applying the effects at an appropriate level?</li> <li>• Are microphone connected to the MIC input jacks?</li> <li>• If you are using condenser microphone, is the PHANTOM +48V switch turned on?</li> </ul>
<p><b>No effect is applied</b></p>	<ul style="list-style-type: none"> <li>• Check that the EFFECT control on each channel is correctly adjusted.</li> <li>• Be sure that the FX control and EFFECT fader are correctly adjusted.</li> </ul>
<p><b>I want spoken words to be heard more clearly.</b></p>	<ul style="list-style-type: none"> <li>• Adjust the equalizers on each channel.</li> </ul>
<p><b>I want to output a monitor signal through speakers.</b></p>	<ul style="list-style-type: none"> <li>• Connect a powered speaker to the AUX jack, or to the AUX1 or 2 jack and turn the PRE switch on each channel on. Then adjust the output signal by using the AUX controls on each channel.</li> </ul>
<p><b>The level meter doesn't show the output signal level.</b></p>	<ul style="list-style-type: none"> <li>• Are the PEL switches for the channels that you are not using turned on?</li> </ul>



## CE Declaration of Conformity

Importer: TRONIOS BV  
Bedrijvenpark Twente 415  
7602 KM - ALMELO

Tel : 0031546589299  
Fax : 0031546589298  
The Netherlands

Product number: 171.142, 171.144, 171.147, 171.151

Product Description:

**PDM-S803 Stage Mixer 8Ch DSP/MP3**  
**PDM-S1203 Stage Mixer 12Ch DSP/MP3**  
**PDM-S1603 Stage Mixer 16Ch DSP/MP3**  
**PDM-S1203A Ampl. Mixer 12ch DSP/MP3**

Regulatory Requirement: EN 60065:2002+A1:2006+A11:2008  
EN 55103-1:1996  
EN 55103-2:1996  
EN 61000-3-2/-3-3:2006  
EN 61000-4-2:2001 to  
EN 61000-4-11:2004

The product met the requirements stated in the above mentioned Declaration(s).

ALMELO,  
17-02-2011

Signature :

A handwritten signature in black ink, appearing to be 'J. de' or similar, written in a cursive style.

**[www.tronios.com](http://www.tronios.com)**

Copyright © 2011 by TRONIOS the Netherlands