

beamZ

LS-FBTRI RGB Laser DMX



152.903

Instruction Manual

WARNING

**FOR YOUR OWN SAFETY, PLEASE READ THIS USER MANUAL CAREFULLY
BEFORE YOUR INITIAL START-UP!**

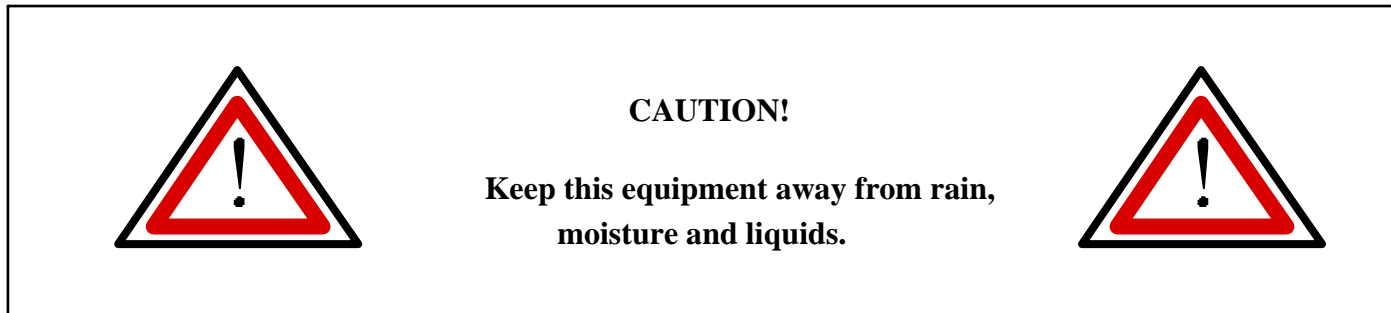

SAFETY INSTRUCTIONS

Every person involved with the installation, operation & maintenance of this equipment should:

- Be competent
- Follow the instructions of this manual

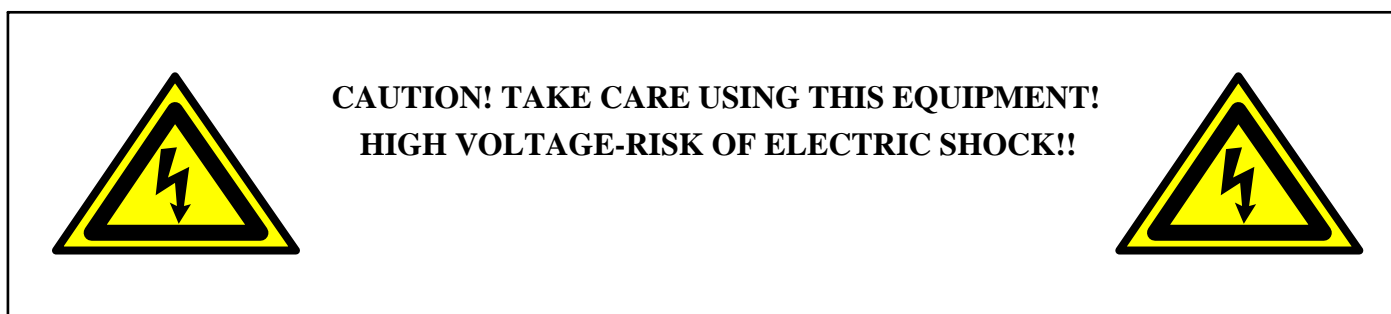

Before your initial start-up, please make sure that there is no damage caused during transportation. Should there be any, consult your dealer and do not use the equipment.

To maintain the equipment in good working condition and to ensure safe operation, it is necessary for the user to follow the safety instructions and warning notes written in this manual.

Please note that damages caused by user modifications to this equipment are not subject to warranty.

IMPORTANT:

The manufacturer will not accept liability for any resulting damages caused by the non-observance of this manual or any unauthorized modification to the equipment.

- Never let the power-cable come into contact with other cables. Handle the power-cable and all mains voltage connections with particular caution!
- Never remove warning or informative labels from the equipment.
- Do not open the equipment and do not modify the equipment.
- Do not connect this equipment to a dimmer-pack.
- Do not switch the equipment on and off in short intervals, as this will reduce the system's life.
- Only use the equipment indoors.
- Do not expose to flammable sources, liquids or gases.
- Always disconnect the power from the mains when equipment is not in use or before cleaning! Only handle the power-cable by the plug. Never pull out the plug by pulling the power-cable.
- Make sure that the available voltage is between 220v/240v.
- Make sure that the power-cable is never crimped or damaged. Check the equipment and the power-cable periodically.
- If the equipment is dropped or damaged, disconnect the mains power supply immediately. Have a qualified engineer inspect the equipment before operating again.
- If the equipment has been exposed to drastic temperature fluctuation (e.g. after transportation), do not switch it on immediately. The arising condensation might damage the equipment. Leave the equipment switched off until it has reached room temperature.
- If your product fails to function correctly, discontinue use immediately. Pack the unit securely (preferably in the original packing material), and return it to your Prolight dealer for service.
- Only use fuses of same type and rating.
- Repairs, servicing and power connection must only be carried out by a qualified technician. **THIS UNIT CONTAINS NO USER SERVICEABLE PARTS.**
- **WARRANTY;** One year from date of purchase.

OPERATING DETERMINATIONS

If this equipment is operated in any other way, than those described in this manual, the product may suffer damage and the warranty becomes void.

Incorrect operation may lead to danger e.g.: short-circuit, burns, electric shocks, lamp failure etc.

Do not endanger your own safety and the safety of others!

Incorrect installation or use can cause serious damage to people and property.

You should find inside the Laser carton the following items:

- 1, Trinity Beam Laser 2, Power cable 3, User manual 4, Safety Keys

Technical Specifications:

DMX channels: 2

Laser diodes: 1 x 80mW Green (532nm) DPSS laser, 1 x 400mW Blue (450nm) DPSS laser
1 x 300mW Red (650nm) DPSS laser

Operating modes: 1, Sound Active
 2, Auto Run
 3, DMX
 4, Master/slave

Power consumption: 220W

Power supply: 240V - 50Hz

Dimensions: 350 x 392 x 110mm

Weight: 4.6Kgs

Fuse: 2A

Features:

The Beam Laser features 7 DMX channels and many laser patterns that are ideal with or without fog.

Back view:

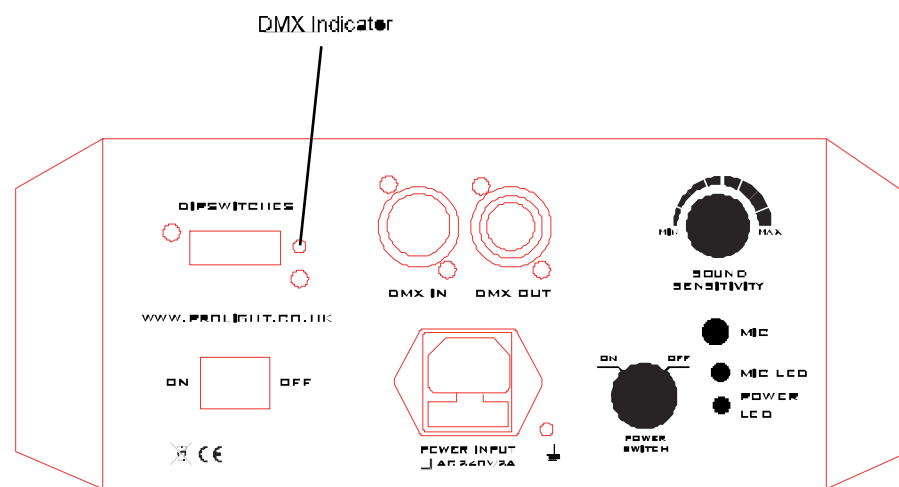

Hanging bracket positioning:

When you first open the carton, you will notice that the hanging bracket is placed on back of the unit, this is for installation set up.

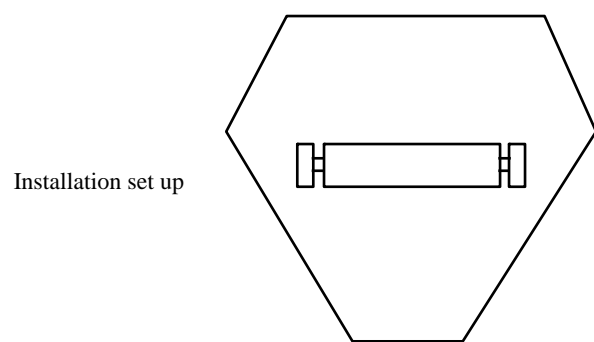

Operation modes:

The Beam laser has 4 modes of operation as follows:

1, Sound active mode

To select sound active mode set dip switch 10 to **ON** and all others to **OFF**. You can now use the sensitivity control on the back panel to set the required sound level.

2, Auto run mode

To select auto pattern mode, set dip switch 9 and 10 to the **ON** position and all others to **OFF**. The Trinity Beam will now cycle through all it's internal patterns.

3, DMX mode

To select DMX mode, set dip switch 10 to **OFF**. You can now set the required DMX address using dip switches 1 to 9. Please refer to the chart below for DMX functions.

The DMX address starts at 1.

4, Master/slave mode

To set the unit/s in slave mode, set dip switch 3 to the **ON** position and all others to **OFF**. The Trinity Beam laser/s will now run in sequence with the master unit.

Example:

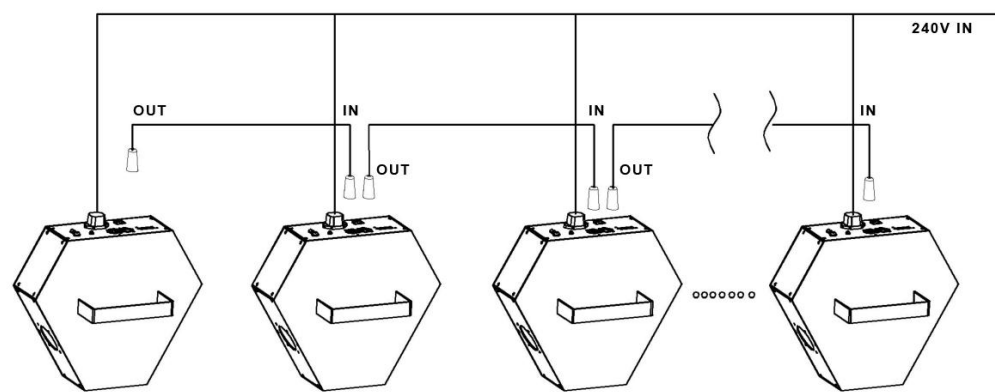

DMX function chart:

Channel	DMX Address	Function
CH.1	0-70	Blackout
	71-140	Sound active
	141-210	Auto run
	211-255	DMX manual mode
CH.2	0-255	28 Pattern selector (CH.1, DMX manual mode)

DMX Control Mode

Operating in a DMX control mode environment gives the user the greatest flexibility when it comes to customising or creating a show. In this mode you will be able to control each individual trait of the fixture and each fixture independently.

Setting the DMX address

The DMX mode enables the use of a universal DMX controller. Each fixture requires a “start address” from 1- 511. A fixture requiring one or more channels for control begins to read the data on the channel indicated by the start address. For example, a fixture that occupies or uses 7 channels of DMX and was addressed to start on DMX channel 100, would read data from channels: 100,101,102,103,104,105 and 106. Choose a start address so that the channels used do not overlap. E.g. the next unit in the chain starts at 107.

Set the start address using the group of dip switches located usually on the back of the fixture. Each dip switch has an associated value. Adding the value of each switch in the ON position will provide the start address. Determining which switches to toggle ON given a specific start address can be accomplished in the following manner. By subtracting the largest switch value possible from the selected start address until zero is achieved.

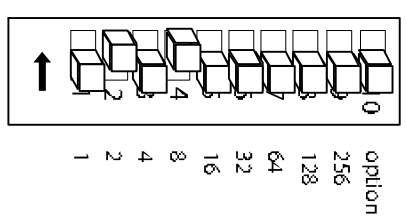
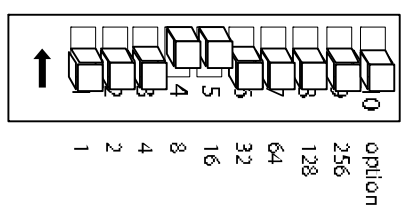
EXAMPLE STARTING ADDRESS																								
<p>Address 10</p> <p>Pin NO: 4 = 8 Pin NO: 2 = 2 Total = 10</p>	<p>on</p> 																							
<p>Address 24</p> <p>Pin NO: 5 = 16 Pin NO: 4 = 8 Total = 24</p>	<p>on</p> 																							
<p>DMX address using simple maths</p>	<p>233 - (128 = 105, Turn on dip No: 8 105 - (64) = 41, Turn on dip No:7 41 - (32) = 9, Turn on dip No: 6 9 - (8) = 1, Turn on dip No: 4 1 - (1) = 0, Turn on dip No:1</p> <p>You will most likely use the first available number which maybe Number 1. This number was selected for example purposes</p>	<table border="1"> <thead> <tr> <th>DIP SWITCH</th> <th>(DMX VALUE)</th> </tr> </thead> <tbody> <tr><td>1</td><td>1</td></tr> <tr><td>2</td><td>2</td></tr> <tr><td>3</td><td>4</td></tr> <tr><td>4</td><td>8</td></tr> <tr><td>5</td><td>16</td></tr> <tr><td>6</td><td>32</td></tr> <tr><td>7</td><td>64</td></tr> <tr><td>8</td><td>128</td></tr> <tr><td>9</td><td>256</td></tr> <tr><td>10</td><td></td></tr> </tbody> </table>	DIP SWITCH	(DMX VALUE)	1	1	2	2	3	4	4	8	5	16	6	32	7	64	8	128	9	256	10	
DIP SWITCH	(DMX VALUE)																							
1	1																							
2	2																							
3	4																							
4	8																							
5	16																							
6	32																							
7	64																							
8	128																							
9	256																							
10																								

DMX-512:

- DMX (Digital Multiplex) is a universal protocol used as a form of communication between intelligent fixtures and controllers. A DMX controller sends DMX data instructions from the controller to the fixture. DMX data is sent as serial data that travels from fixture to fixture via the DATA “IN” and DATA “OUT” XLR terminals located on all DMX fixtures (most controllers only have a data “out” terminal).

DMX Linking:

- DMX is a language allowing all makes and models of different manufactures to be linked together and operate from a single controller, as long as all fixtures and the controller are DMX compliant. To ensure proper DMX data transmission, when using several DMX fixtures try to use the shortest cable path possible. The order in which fixtures are connected in a DMX line does not influence the DMX addressing. For example; a fixture assigned to a DMX address of 1 may be placed anywhere in a DMX line, at the beginning, at the end, or anywhere in the middle. When a fixture is assigned a DMX address of 1, the DMX controller knows to send DATA assigned to address 1 to that unit, no matter where it is located in the DMX chain.

DATA Cable (DMX cable) requirements (for DMX operation):

- The Beam laser can be controlled via DMX-512 protocol. The DMX address is set on the back of the unit. Your unit and your DMX controller require a standard 3-pin XLR connector for data input/output (figure 1).

Figure 1

Also remember that DMX cable must be daisy chained and cannot be split.

Notice:

- Be sure to follow figures 2 & 3 when making your own cables. Do not connect the cable's shield conductor to the ground lug or allow the shield conductor to come in contact with the XLR's outer casing. Grounding the shield could cause a short circuit and erratic behaviour.

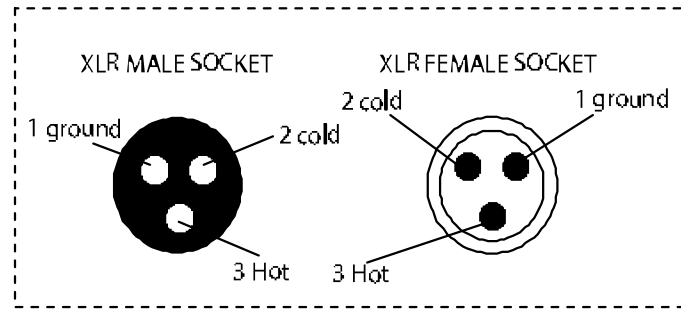
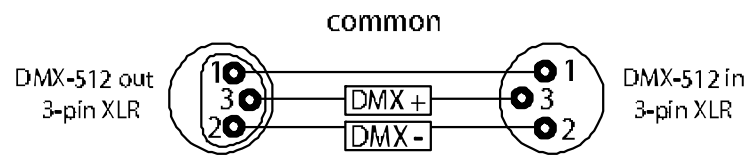

XLR Pin Configuration
Pin 1 = Ground
Pin 2 = Negative
Pin 3 = Postive

FIGURE 3

FIGURE 2

Special Note: Line termination:

- When longer runs of cable are used, you may need to use a terminator on the last unit to avoid erratic behaviour.

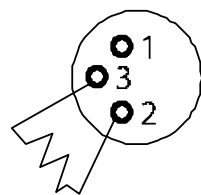

Termination reduces signal transmission problems and interference. it is always advisable to connect a DMX terminal, (resistance 120 Ohm 1/4 W) between pin 2 (DMX-) and pin 3 (DMX+) of the last fixture.

Using a cable terminator (part number CABL90) will decrease the possibilities of erratic behaviour.

5-Pin XLR DMX Connectors:

- Some manufactures use 5-pin XLR connectors for data transmission in place of 3-pin. 5-Pin XLR fixtures may be implemented in a 3-pin XLR DMX line. When inserting standard 5-pin XLR connectors in to a 3-pin line a cable adaptor must be used. The Chart below details the correct cable conversion.

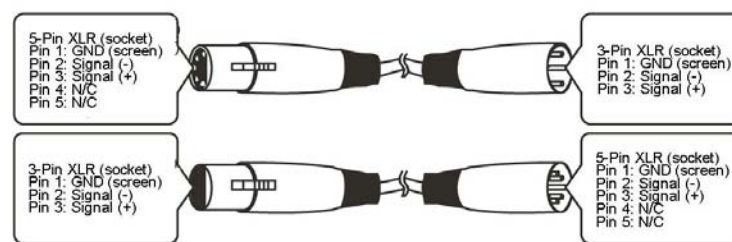

DMX Dip Switch Quick Reference Chart

Dip Switch Position

DMX DIP SWITCH SET 0=OFF 1=ON					#9	0	0	0	0	0	0	0	0	1	1	1	1	1	1	1	1		
					#8	0	0	0	0	1	1	1	1	0	0	0	0	1	1	1	1	1	1
					#7	0	0	1	1	0	0	1	1	0	0	1	1	0	0	1	1	1	1
					#6	0	1	0	1	0	1	0	1	0	1	0	1	0	1	0	1	0	1
#1	#2	#3	#4	#5																			
0	0	0	0	0		32	64	96	128	160	192	224	256	288	320	352	384	416	448	480			
1	0	0	0	0	1	33	65	97	129	161	193	225	257	289	321	353	385	417	449	481			
0	1	0	0	0	2	34	66	98	130	162	194	226	258	290	322	354	386	418	450	482			
1	1	0	0	0	3	35	67	99	131	163	195	227	259	291	323	355	387	419	451	483			
0	0	1	0	0	4	36	68	100	132	164	196	228	260	292	324	356	388	420	452	484			
1	0	1	0	0	5	37	69	101	133	165	197	229	261	293	325	357	389	421	453	485			
0	1	1	0	0	6	38	70	102	134	166	198	230	262	294	326	358	390	422	454	486			
1	1	1	0	0	7	39	71	103	135	167	199	231	263	295	327	359	391	423	455	487			
0	0	0	1	0	8	40	72	104	136	168	200	232	264	296	328	360	392	424	456	488			
1	0	0	1	0	9	41	73	105	137	169	201	233	265	297	329	361	393	425	457	489			
0	1	0	1	0	10	42	74	106	138	170	202	234	266	298	330	362	394	426	458	490			
1	1	0	1	0	11	43	75	107	139	171	203	235	267	299	331	363	395	427	459	491			
0	0	1	1	0	12	44	76	108	140	172	204	236	268	300	332	364	396	428	460	492			
1	0	1	1	0	13	45	77	109	141	173	205	237	269	301	333	365	397	429	461	493			
0	1	1	1	0	14	46	78	110	142	174	206	238	270	302	334	366	398	430	462	494			
1	1	1	1	0	15	47	79	111	143	175	207	239	271	303	335	367	399	431	463	495			
0	0	0	0	1	16	48	80	112	144	176	208	240	272	304	336	368	400	432	464	496			
1	0	0	0	1	17	49	81	113	145	177	209	241	273	305	337	369	401	433	465	497			
0	1	0	0	1	18	50	82	114	146	178	210	242	274	306	338	370	402	434	466	498			
1	1	0	0	1	19	51	83	115	147	179	211	243	275	307	339	371	403	435	467	499			
0	0	1	0	1	20	52	84	116	148	180	212	244	276	308	340	372	404	436	468	500			
1	0	1	0	1	21	53	85	117	149	181	213	245	277	309	341	373	405	437	469	501			
0	1	1	0	1	22	54	86	118	150	182	214	246	278	310	342	374	406	438	470	502			
1	1	1	0	1	23	55	87	119	151	183	215	247	279	311	343	375	407	439	471	503			
0	0	0	1	1	24	56	88	120	152	184	216	248	280	312	344	376	408	440	472	504			
1	0	0	1	1	25	57	89	121	153	185	217	249	281	313	345	377	409	441	473	505			
0	1	0	1	1	26	58	90	122	154	186	218	250	282	314	346	378	410	442	474	506			
1	1	0	1	1	27	59	91	123	155	187	219	251	283	315	347	379	411	443	475	507			
0	0	1	1	1	28	60	92	124	156	188	220	252	284	316	348	380	412	444	476	508			
1	0	1	1	1	29	61	93	125	157	189	221	253	285	317	349	381	413	445	477	509			
0	1	1	1	1	30	62	94	126	158	190	222	254	286	318	350	382	414	446	478	510			
1	1	1	1	1	31	63	95	127	159	191	223	255	287	319	351	383	415	447	479	511			

