



I N S T R U C T I O N M A N U A L

Star Cluster Micro

Compact star cluster lasers with multi FX

M A N U A L V E R S I O N 2 . 0
1 5 - 1 1 - 1 1

Due to continuous product development, please ensure that you have downloaded the latest instruction manual for this product from the Kam website at www.kam.co.uk

For the latest updates and information on the entire Kam range visit:

www.kam.co.uk

Kam products are manufactured by: **Lamba plc**, Unit 1, Southfields Road, Dunstable, Bedfordshire, United Kingdom LU6 3EJ

Telephone: (+44) (0)1582 690600 • Fax: (+44) (0)1582 690400 • Email: mail@lambapl.com • Web: www.lambapl.com

If this product is ever no longer functional please take it to a recycling plant for environmentally friendly disposal.

Due to continuous product development, specifications and appearance are subject to change. © Copyright Lamba plc 2011. E&OE.

Thank you for purchasing this Kam product, we are sure that it will serve you for many years to come.

To optimise the performance of this product, please read these operating instructions carefully to familiarise yourself with the basic operations of this unit. Please retain them for future reference. This unit has been tested at the factory before being shipped to you.

To prevent or reduce the risk of electrical shock or fire, do not expose the unit to rain or moisture. To prevent a fire hazard, do not expose the unit to any naked flame sources. Unplug this apparatus during lightning storms or if it is unlikely to be used for long periods of time.

When installing the unit, please ensure you leave enough space around the unit for ventilation. Slots and openings in the unit are provided for ventilation to ensure reliable operation of the product and to protect it from overheating. To prevent fire hazard, the openings should never be blocked or covered.

Always handle the power cable by the plug. Never pull out the plug by pulling on the cable. Never touch the power cable when your hands are wet as this could cause an electric shock. Do not tie a knot in the cable. The power cable should be placed such that it is not likely to be stepped on. A damaged power cable can cause a fire or give you an electrical shock. Check the power cord periodically, if you ever find that it is damaged, replace it before using the unit again. Contact your retailer for a replacement.

The voltage of the available power supply differs according to country or region. Be sure that the power supply voltage of the area where this unit is to be used meets the required written on the unit.



The lightning flash symbol inside a triangle is to alert the user to the presence high voltage within the unit's enclosure that may be of sufficient power to constitute a risk of electrical shock to persons.

Caution: to prevent the risk of electric shock, do not attempt to open the unit. No user-serviceable parts inside. Refer all servicing to qualified service personnel.

The exclamation mark inside a triangle is intended to alert the user to the presence of important operating and maintenance instructions in the literature accompanying the appliance.

Select the installation location of your unit carefully. Avoid placing it in direct sunlight or locations subject to vibration and excessive dust. Do not use the unit where there are extremes in temperature (below 41°F / 5°C or exceeding 95°F / 35°C).

Unpacking and safety Please unpack your new product carefully. Your new product should reach you in perfect condition. Please check that no damage has occurred during transit. If any damage is found, do not operate your unit. Please contact the retailer you purchased it from immediately. If there is any damage to the mains cable do not use the device. Always disconnect the unit from the mains supply when carrying out any cleaning of the unit.

Operation

The Kam Star Cluster Micro is an easy to operate star cluster laser. There are two modes of operation; Sound-to-Light and Automatic. The unit can be controlled on the chassis or via the remote control. The unit is powered by the supplied adapter or via in-car/boat/travel adapter. To start the unit plug in either power supply to the back of the unit, it will begin to operate immediately but to work at its full power, please allow between five and ten minutes to warm up. The unit will only begin emitting its laser effect when the key on the rear of the unit has been inserted and turned to the On position. The unit will stop emitting the laser if the key is removed. When you power up the unit, ensure that the laser is not pointing towards anyone's eyes. Pressing the mode button on the front of the unit for 2.5 seconds will turn the unit Off/On.

Auto mode

When the unit is working in Auto mode it runs through a series of pre-programmed patterns. To activate Auto mode, click the Mode Select button on the front of the unit or choose 'Auto' on the remote control. When the unit is operating in Auto mode the indicator LED light on the front of the unit will glow red.

Sound-to-Light mode

The unit has a built-in microphone that monitors any loud ambient sounds including music. The laser then reacts to this sound and displays a lightshow that matches the rhythm. To activate Sound-to-Light mode, click the Mode Select button on the front of the unit or choose 'Music' on the remote control. When the unit is operating in Sound-to-Light mode the indicator LED light on the front of the unit will glow blue. You can adjust the sensitivity of the microphone on the remote by choosing 'Music' mode and then pressing any number between 1-9 (1 is the least sensitive and 9 is the most sensitive).

Manual mode

The unit can be controlled in Manual mode via the remote control by clicking on the third row buttons A, B or C (G). The A button controls the units red strobing, this is adjusted using the buttons 1-9. The B button controls the unit's second colour strobing, this is adjusted using the buttons 1-9. The C button controls the units effect speed, this is adjusted using the buttons 1-9. The bottom right button (H) controls the effect rotation.

Remote control

The unit can be operated by the supplied remote control. Make sure the unit is powered up and working, if no lasers are showing, press the red power button on the remote (A). Use this button to place the unit in standby mode when it is not needed. To completely turn the unit off, remove the power supply. The remote control's **Auto** button (C) sets the unit to Auto mode (see above). The **Music** button (B) sets the unit to Sound-to-Light mode (see above). The two outer buttons in the second row of the remote (D and E) control the colour that the unit displays. The middle button of the second row (F) pauses the effect.

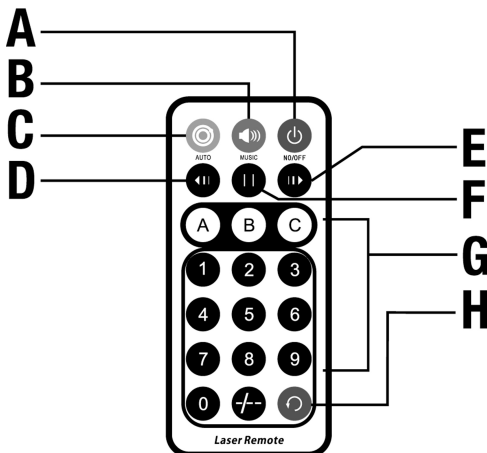

Adjustable green laser (not applicable to red & blue laser)

The brightness of the green laser is adjustable. To increase or decrease the brightness, turn the Green Laser Power knob on the back of the unit clockwise or anticlockwise.

Tripod mount

The unit can be mounted on the supplied tripod mount. Ensure that the unit is not plugged in, then screw the tripod to the underside of the chassis. Spread the tripod's legs and set in position.

Universal mounting bracket

If you wish to permanently position the unit, screw the universal mounting bracket to a surface using raw plugs where necessary. Attach the unit to the bracket with the screw mount. You can adjust the position of the laser by loosening the ball and socket joints and tightening them when you are happy with the direction the unit is pointing in. Make sure that the laser is never pointing in anyone's eyes.

The unit is a class 3B laser, before operation, please read the safety guide that was supplied with the unit.

Specifications

Laser power (dependent on model):

Green - 50mW@532nm (adjustable) - if applicable

Red - 100mW@650nm

Blue - 80mW 450nm blue - if applicable

Beam diameter: <5mm at aperture

Pulse date: All pulses <4Hz (>0.25 sec)

Divergence (each beam): <2 mrad

Divergence (total light): 160 degrees

External power supply: AC 100V-240V / 50Hz-60Hz

Adapter: DC12V / 0.6A

Working environment: 10-40°c indoor

Full warm-up time: 5-10 minutes

Laser safety class: Class 3B

Dimensions: 117mm x 92mm x 46mm

Net weight: 0.35Kg

Features

Complete portable and compact laser kit

Full multi-function remote control

High quality temperature controlled diodes

Selectable multi star cluster effects

Built-in animated patterns

Sound-to-Light and Auto modes

Tough all-metal chassis

Mini tripod

Universal mounting bracket

12v travel adapter

Full instruction manual

Laser safety guide