



Spec Sheet

ES503

3-amped Stereo System
8x3" / 1x12", 1000W Power Amp **digipro G3**



Applications

- Portable PA for live sound and playback applications, clubs, ballrooms, corporate AV
- Compact live sound reinforcement system

Features

- 3-amped stereo system
- OLED DSP Interface
- Stereo or Mono configuration
- On board 3-channel digital mixer
- Built-in extended range Bluetooth® stereo audio receiver
- Customizable balanced output channel
- Logarithmic column array for extended vertical coverage
- Double-ringed phase plugs
- Auto range PSU

Description

ES503 is a 1000W 3-amped sound system composed by 2 slave 4x 3" full-range tops and 1 master 12" subwoofer. The sub hosts a Digipro G3® amp module with auto-range PSU and a 3-channels mixer with Bluetooth connection. The internal design of the tops allows an asymmetrical vertical coverage (thanks to the Logarithmic Curved Column Array technology) and a unique "double ringed" phase plug widens the horizontal coverage and guarantees a perfect voice intelligibility.

The 3 elements composing the system (2 tops and 1 sub) can be configured in 3 different modes:

- 1 MONO MODE
- 2 STEREO MODE
- 3 DOUBLE COLUMN MODE

The enclosure of the two satellites embeds a slide connection system, which assures perfect

top-to-top matching without the risk of incorrect assembly and includes the electrical connection between the two tops. The "A" satellite receives the powered signal from the subwoofer through a 4-poles male Speakon™ connector (included in the box) and relaunch the audio to the "B" top.

The ES503 is equipped with a three-channel mixer controlled by a DSP.

The first channel features a MIC/instrument balanced/unbalanced combo connector with an adjustable anti-feedback filter, impedance compensation and microphone gain with 3 positions (0, +10, +20dB). The second and third channels are LINE inputs with balanced/unbalanced combo connector. The system is provided with several preset equalizations, and each user can create and save its own custom equalization.

The balanced AUX/MIX output can be used as a direct link, or, alternatively, as an AUX output. In this case, you can actually feed a stage monitor or another speaker for which a custom separate mix is needed. In addition to that, a dedicated notch filter is available in order to avoid any feedback.

The system is equipped with a built-in extended range Bluetooth® stereo module, which receives audio from devices such as mobile phones, tablets or any other audio device with a Bluetooth® connection.

ES503 comes with an intuitive wizard that guides the user step-by-step and automatically configures the system according to the application. The advanced graphical interface allows to recall configuration presets, adjust levels, EQ and create a pre/post gain mix for different purposes. A rotary encoder with button allows to control any operation easily and quickly.

The bass-reflex subwoofer houses a 12" woofer and the amplifier module. In addition to the input connectors and controls of the user-interface, there are two Speakon outputs and a VDE power connector. The enclosure, is made of birch plywood coated with a durable scratch-resistant black coat.

ES503

Technical Specifications

Technical Data

Speaker Type	3-amped Stereo System with two full-range tops and one subwoofer
--------------	--

Acoustical Data

Frequency Response [-10dB]	37 - 15.000 Hz
Max SPL	121 dB
MF-HF	8x 3"
MF-HF Type	Neodymium
LF	1x 12"
Directivity	95x65°

Amplifier

Amp Technology	Digipro® G3
Amp Class	Class-D
Power Amp	1000 W
Controls	1x OLED display + rotative knob w/push-button 1x Audio signal monitoring LED 1x mini USB B port (service data)
Power Supply	SMPS with PSU Auto-range
Power Connection	VDE socket
Cooling	Convection

Processor

Controller	DSP 56 bit
Converter AD/DA	24 Bit/48 kHz
Factory Presets	Flat, Playback, Club, Vocal, Monitor, Antifeedback
User Presets	Low Shelving, Semiparametric Filter, High Shelving
Limiter	Dual Active, Peak, RMS, Thermal
Crossover Frequency LF-MF	206 Hz

Inputs

Mic/Instrument Channel	1x Combo (XLR/Jack) balanced/unbalanced input
Line Channels	2x Combo (XLR/Jack) balanced/unbalanced inputs
Media Channel	1x built-in hi-range stereo Bluetooth® audio receiver
Mix Output	1x XLR balanced output

Mechanics

Housing (Subwoofer)	15mm Black Painted Birch Plywood
Housing (Tops)	Polypropylene PP
Handles	2x lateral side (Subwoofer)
Dimensions WxHxD (Tops)	95x360x137 mm – 3.74x13.98x5.39 in
Dimensions WxHxD (Subwoofer)	465x400x430 mm - 18.3x15.7x16.9 in
Weight (1 Top)	1.9Kg – 4.19lbs.
Weight (Subwoofer)	16.4Kg – 36.16lbs.

ES503

Technical Specifications

Rear Panel

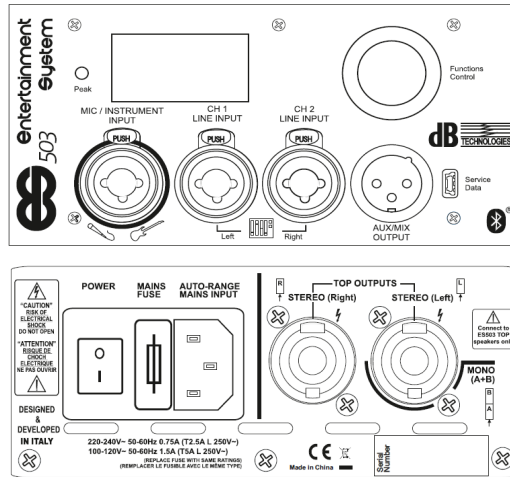

Overall Dimensions

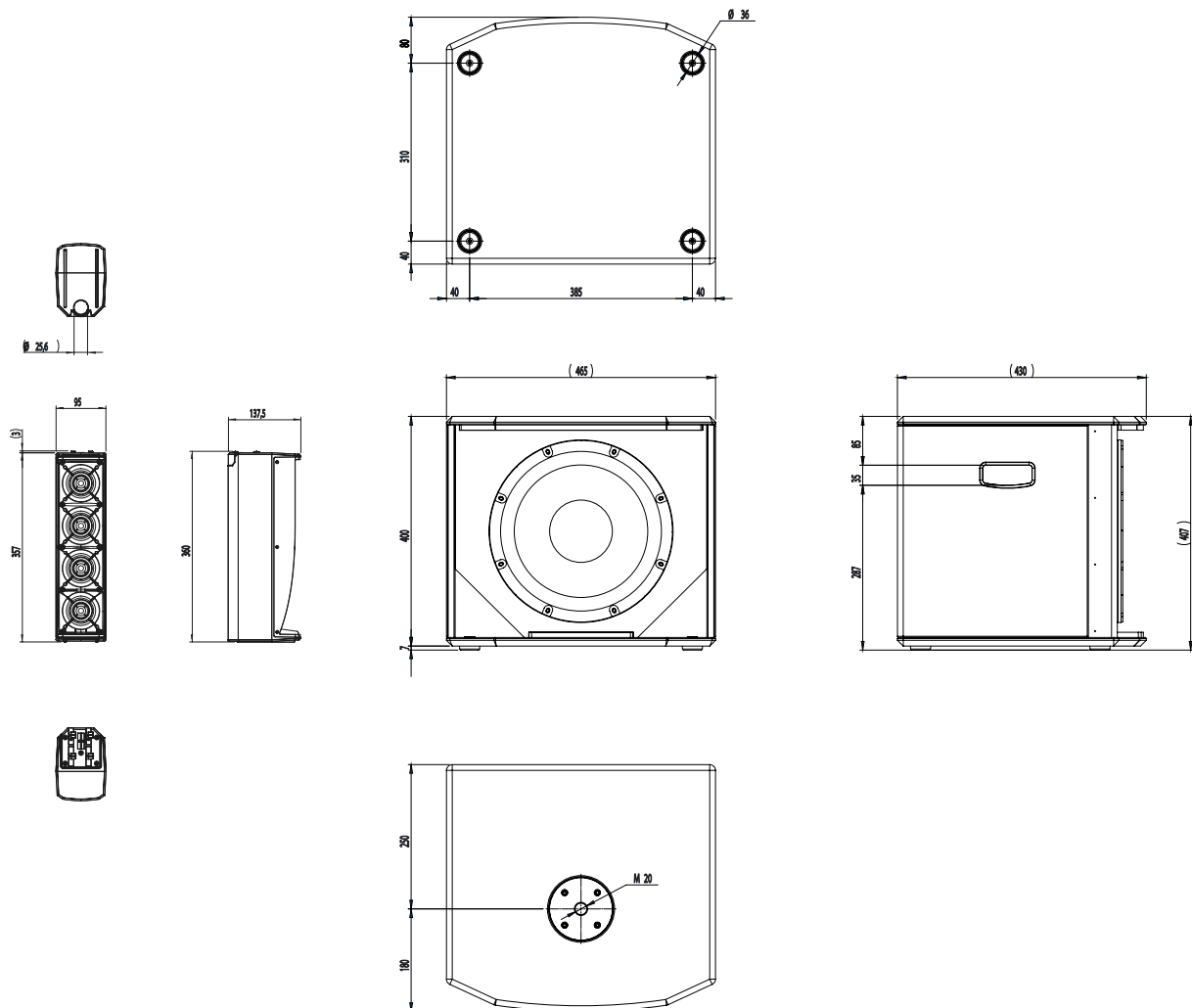

ES503

Technical Specifications

Possible configurations



SINGLE COLUMN MODE, 1x stand pole

In the first option the two satellites are connected top-on-top and are placed on the subwoofer through the supplied D25mm pole. The system is used in mono so all inputs are routed to both outputs in mono. Of course the user can adjust volumes, 3-band EQ and send a second mix with different levels to the AUX/MIX output.

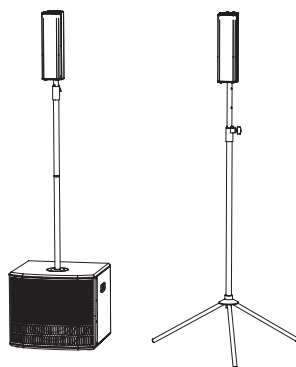

SINGLE STEREO MODE, 2x tripods or 1x stand pole and 1x tripod

This second option implies the use of two tripods and two optional Speakon-Speakon cables to connect the subwoofer to the tops placed on tripods. The system is in stereo: The Mic/Instrument input is assigned to both channels; CH1/LINE L (and Bluetooth® L) is assigned to Output L; CH2/LINE R (and Bluetooth® R) is assigned to Output R. Of course the user can adjust volumes and EQ. He can also prepare a second mix with different levels for the AUX / MIX output.

[Stereo kit ES503 is required for this configuration]

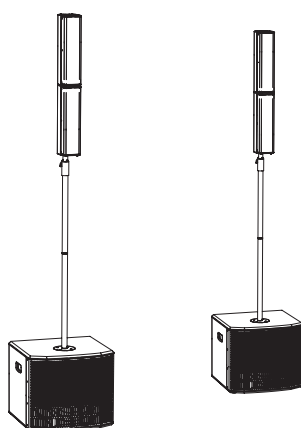

DOUBLE COLUMN MODE, 2x ES 503 in single column mode

The third option uses two ES 503 systems in single column mode: one of the two becomes the master for the second, feeding the signal thanks to the integrated balanced output channel. This way, both system are driven by the master's on-board mixer and any setup is guided through the master's OLED display.

[A second ES503 and DCK-4P are required for this configuration]

What's included in ES503

1x ES Top A

1x ES Top B

1x ES503 sub

1x telescopic pole

1x Speakon cable

1x power supply cable

Accessories

DCK-4P	Kit composed by 2x 7m speakon cables (4 poles)
DT-50	Trolley for ES503 and SUB 28D+2x L 160D
SK-25TT	Kit composed by 2x Tripods (D25mm) + bag
Stereo Kit ES503	Kit composed by 2x tripods + bag for tripods + 2x 7m spakon cables
TC-ES12	Bag for ES503 and ES802 subs
TC-ESTOP	Bag for 2 ES tops or 2 L80D
TK-ES12	Transport kit for ES503 and ES802 (trolley + bags)

info@dbtechnologies.com www.dbtechnologies.com

dBTechnologies products are continually improved. All specifications are therefore subject to change without notice.