



Ref. Nr. 150.570



# **WI-BAR 192 LED RGB BATTERY 2.4GHZ DMX**

## **MANUAL**

Thank you for purchasing our company products. Please read these instructions carefully to enjoy optimum performance and a longer service life before you start to use.

**CONTENTS**

CONTENTS ..... 2

Unpacking Inspections ..... 3

    Unpacking instructions ..... 3

    Checking the contents of the carton:..... 3

Safety Instructions ..... 3

Product Overview ..... 4

Functions Introductions ..... 4

    Main Functions ..... 4

    Operation Instructions ..... 5

        Power supply connecting: ..... 5

        Control panel operation ..... 5

DMX Mode..... 6

    Set DMX adres ..... 6

Act mode (Standalone) ..... 8

IR control ..... 9

    Automatic Mode..... 9

    Sound Active Mode ..... 9

    Manual Color Control..... 9

DMX Mode Auto Sync ..... 10

    For the transmitting product..... 10

    For the receiving product(s)..... 10

DMX Mode Manual Sync:..... 10

    For the transmitting product..... 10

    For the receiving product(s)..... 11

IR/standalone mode auto Sync ..... 11

    For the transmitting product:..... 11

    For the receiving product(s)..... 11

Master/slave mode ..... 12

    Standalone master/slave ..... 12

    Master/slave mode with DMX signal ..... 12

    Multi-groups connecting with DMX..... 13

Out-of-factory parameter setup ..... 13

Charge the battery ..... 13

    Reset the software..... 13

Maintenance ..... 14

Specification ..... 14

CE & R&TTE Declaration of Conformity..... 15



## UNPACKING INSPECTIONS

### Unpacking instructions

- Please unpack the carton and check the goods carefully when you receive it , if discover packing damage, shortage or quality problem, please notify the shipper and reject the goods.
- Before using this product, please read the instructions carefully and keep it in a safe place for future reference.

### Checking the contents of the carton:

The product, Power cord, Instruction Manual, Remoter, Bracket, Screws

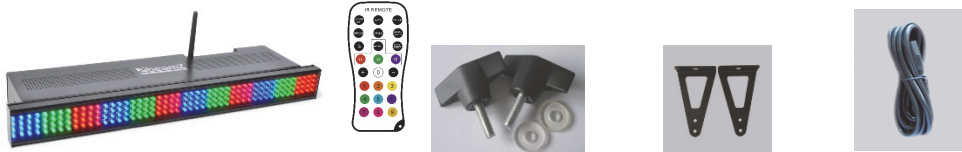

## SAFETY INSTRUCTIONS

- Safety and regulatory power socket with high quality output should be used .
- Always connect the product to a grounded circuit to avoid the risk of electrocution.
- Never put tiny metal objects such as a screwdriver, iron wire and coins, etc. into the internal or stretch into the machine in case of short circuit .
- Please make sure to connect the proper voltage and do not higher or lower than that stated on the decal or rear panel of the product .
- Avoid hitting, crashing or squeezing with other objects in transportation. Never carry the product from the power cord or any moving part . Always use the hanging / mounting bracket or the handles.
- The product is used in door only .
- Never pull or tug on the cord and change it for another one , stop using it when it is damaged or becomes hot .
- Stop using the product once there is sparks when connecting with the power plug .
- Can not operate product with wet hands and never place it near the water or other liquid.
- Make sure there are no flammable materials close to the fixture while operating . Always install it in a location with adequate ventilation.
- Never replace the lighting source with different specification and rating when the original one is damaged.
- Make sure to power off before replacing the light source or the fuse. Never do it while it is on.
- The ambient temperature is no more than 40°C(104°F) .
- Never clean the fixture by water, thinner or other dissolved agent .
- Stop using the product in case of a serious operating problem and send it to our maintenance agent immediately. Never repair by non-professional workers .
- Avoid direct eye exposure to the light source while the product is on.

## PRODUCT OVERVIEW

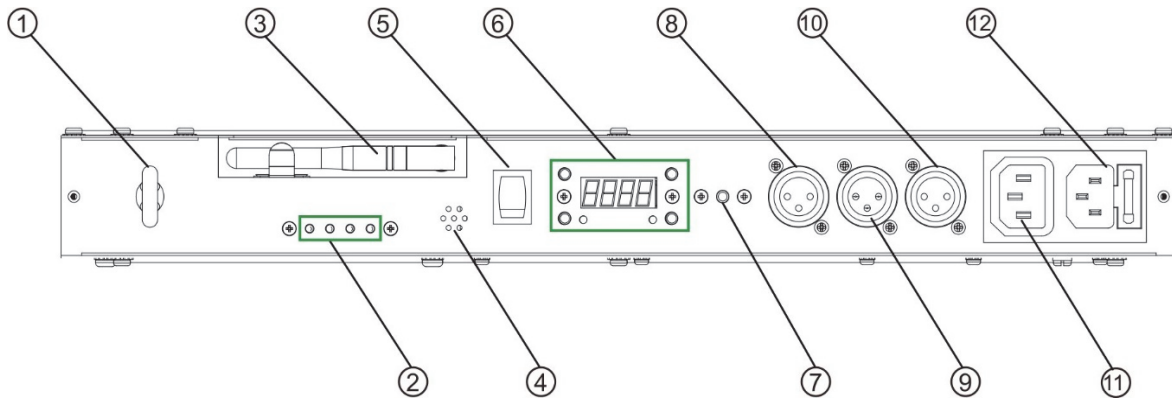

- |                      |                                |
|----------------------|--------------------------------|
| 1. Safety Eyebolt    | 8. DMX signal output           |
| 2. Battery indicator | 9. DMX signal input            |
| 3. Antenna           | 10. Master/Slave signal output |
| 4. Microphone        | 11. Power output               |
| 5. Power on/off      | 12. Power input                |
| 6. Control Panel     | 13. LEDs                       |
| 7. Auto Search       | 14. Bracket                    |

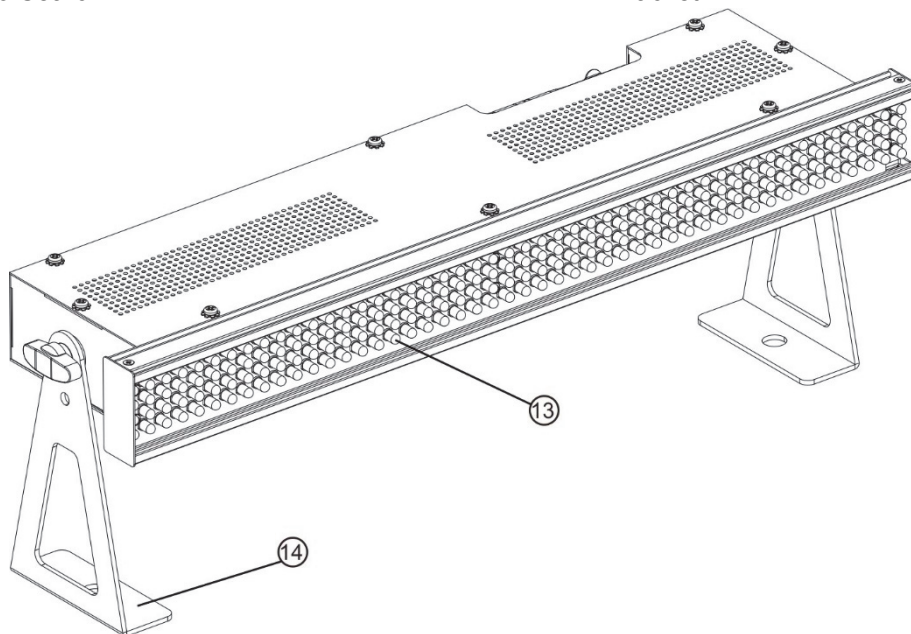

## FUNCTIONS INTRODUCTIONS

### Main Functions

- 3 or 4 DMX channels
- Automatic, sound active and master/slave mode
- Built-in 23 actions, run speed and strobe speed can be adjusted
- With static colors, strobe, dimmer, color mixing and changing effects
- IR Remote control
- Can receive and transmit signal wirelessly

## Operation Instructions

### Power supply connecting:

Two sockets in the product, Power In and Power Out , the product can be supplied power by the power out. Maximum output power of the socket is 480W .

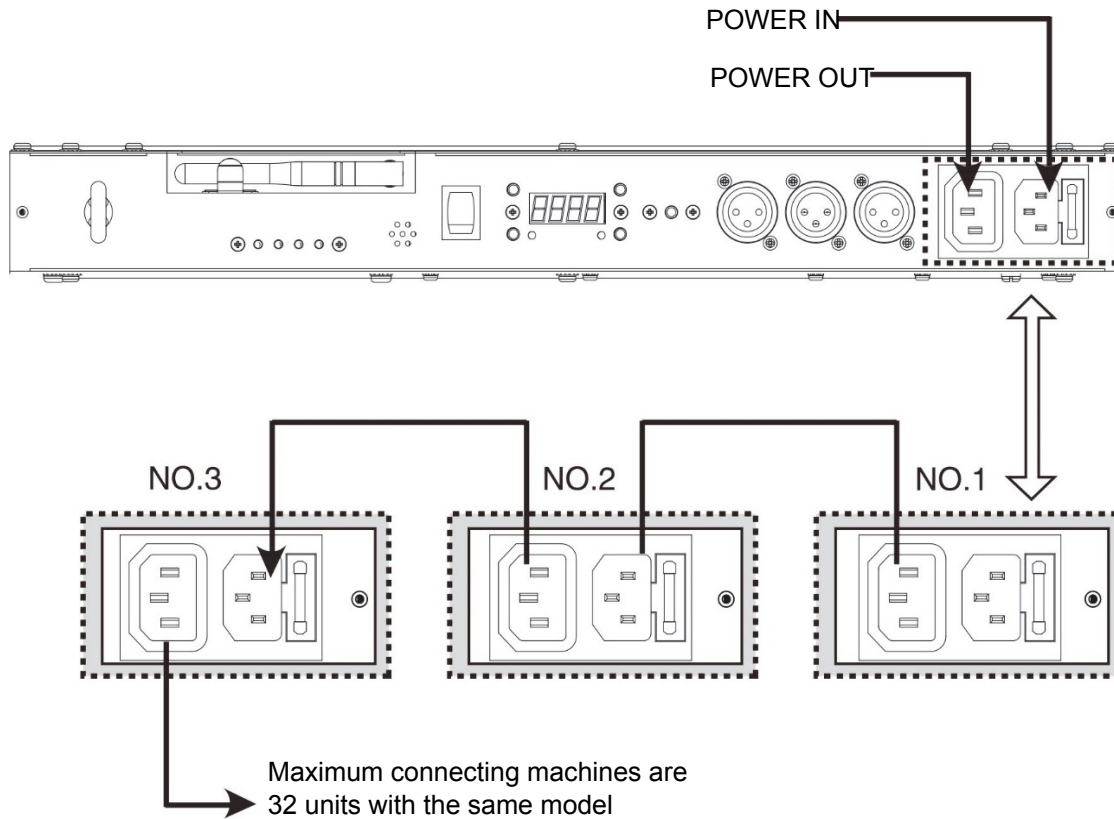

### Control panel operation

Use the four buttons 《MODE》 《ENTER》 《UP》 and 《DOWN》 to operate the control panel:

- SYS System settings
- S-lr IR control
- ACT Action control, stand-alone programs
- SLAU Slave mode, set receive frequency for IR & ACT use

Press 《MODE》 to find an operation mode or to back out of the current menu option.

Press 《UP》 to scroll up the list of options or to find a higher value.

Press 《DOWN》 to scroll down the list of options or to find a lower value.

Press 《ENTER》 to activate a menu option or a selected value.

MODE			Description	
SYS	S dAd		DMX address setup (001-509)	
	d-CH	3CH	3CH DMX mode	
		4CH	4CH DMX mode	
	s-tr	t.CH		Manually select transmit frequency (for IR&Act use) t001-t016
		tA.S		Automatically select Receive frequency (for IR&Act use)
		dt.CH		Manually select Transmit frequency (for DMX use) dt01-t16
		dtA.S		Automatically select Transmit frequency (for DMX use)
		dr.CH		Manually select receive frequency (for DMX use) dr.01-dr.16
	drA.S		Automatically select receive frequency (for DMX use)	
d-SL		Sensitivity low to high (SL.00-SL.32)		
S AAd		Reset software		
S-lr			IR Infrared remote control	
SLAu	rA.S	r-AU	Automatically select receive frequency (For IR&Act use)	
	r-St	r001-r016	Manually select receive frequency (For IR&Act use) r001-r016	
ACt	A000	F000-F100	Strobe speed (slow to fast )	
		SL.00-SL.32	Sensitivity low to high (SL.00-SL.32)	
	A023	P000-P100	Run speed (slow to fast )	
		C000-C100	Brightness adjustment (dark to bright)	

## DMX Mode

### Set DMX adres

When selecting a starting DMX address, always consider the number of DMX channels. If you choose a starting address that is too high, you could restrict the access to some of the product's channels. With 3Ch & 4CH, when in 4-channel DMX mode, it defines the highest configurable address 509.

### Follow below to select the DMX starting address

Press <MODE> repeatedly until SYS, ACt, SLAv, or S-1r shows on the display.

Use <UP> or <DOWN> to select SYS.

Press <ENTER>

Use <UP> or <DOWN> to select SdAd from the menu

Press <ENTER>

Use <UP> or <DOWN> to select the starting address.

Press <ENTER>

### With 3CH and 4CH, follow below to setup

Press <MODE> repeatedly until SYS, ACt, SLAv, or S-1r shows on the display.

Use <UP> or <DOWN> to select SYS

Press <ENTER>

Use <UP> or <DOWN> to select d-CH from the menu

Press <ENTER>

Use <UP> or <DOWN> to select either the 3-channel mode (3CH) or the 4-channel mode (4CH)

Press <ENTER>

### DMX Value Functions 4 CH

CHANNEL	VALUE	FUNCTION	CH 2	CH 3	CH 4
1		<b>Static colors</b>			
	000 – 009	Blackout			
	010 – 019	Red		Flash speed 000 – 249	
	020 – 029	Green			
	030 – 039	Blue		Sound Active 250 – 255	
	040 – 049	Red + Green			
	050 – 059	Red + Blue			
	060 – 069	Blue + Green			
	070 – 079	Red + Green + Blue			
		<b>Color Changes</b>			
	080 – 089	Color change 1		Flash speed 000 – 249	
	090 – 099	Color change 2			
	100 – 109	Quadrant Effect 1		Sound Active 250 – 255	
	110 – 119	Quadrant Effect 2	Run Speed		
	120 – 129	Quadrant Effect 3			
	130 – 139	Quadrant Effect 4	Automatic 000 – 127		
	140 – 149	Quadrant Effect 5			
	150 – 159	Quadrant Effect 6	Sound Active 128 – 255		
	160 – 169	Quadrant Effect 7			
	170 – 179	Quadrant Effect 8			
	180 – 189	Color change 3			
	190 – 199	Color change 4			
	200 – 209	Color change 5			
210 – 219	RGB Color Mix mode	Red 0-100%	Green 0-100%	Blue 0-100%	
220 – 229	Color Mode	Fade speed 0-100%			
230 – 255	Auto Run (sound active only)				

### DMX Value Functions 3 CH

VALUE	CH 1	CH 2	CH 3
000 – 255	RED	GREEN	BLUE

## Act mode (Standalone)

Set the product in one of the standalone modes to control without connecting a DMX controller.

Note: Never connect a product that is operating in any standalone mode to a DMX string connected to a DMX controller.

Follow below actions to setup standalone mode:

Press <MODE> repeatedly until SYS,ACT,SLAv,or S-1r shows on the display.

Use <UP> or <DOWN> to select Act

Press <ENTER>

Use <UP> or <DOWN> to choose your desired program (A000-A023).

Press <ENTER>

Note: Certain programs will have additional functionality. To find these options, press <ENTER> after selecting an auto program. Then press <UP> or <DOWN>. Not every program will feature all the added functionality.

<b>Function:</b>	F000 - F100	SL.00 – SL.32	P000 – P100	C000 – C1000
<b>Description:</b>	Flash speed (slow to fast)	Sound sensitivity	Run speed (slow to fast)	Dimmer

Please refer to below:

Display	Function	Run Speed (P)	Flash Speed (F)	Color (C)	
A000	Black		0 – 100		
A001	Red		0 – 100		
A002	Green		0 – 100		
A003	Blue		0 – 100		
A004	Yellow		0 – 100		
A005	Purple		0 – 100		
A006	Cyan		0 – 100		
A007	White		0 – 100		
A008	Color Change	Run Speed Automatic 0 – 50	0 – 100		
A009	Action 1		0 – 100		
A010	Action 2		0 – 100		
A011	Action 3		0 – 100		
A012	Action 4		Run Speed Sound 51 – 100		
A013	Action 5				
A014	Action 6				
A015	Action 7				
A016	Action 8				
A017	Action 9				
A018	Action 10				
A019	Action 11				
A020	Action 12				
A021	Any Color	0 – 100 (red)	0 – 100 (green)		0 – 100 (blue)
A022	Color Fade	0 – 100			
A023	Auto Run	0 – 100			



## IR control

It is fully compatible with the IRC (Infrared Remote Control), please follow below to setup.  
Press <MODE> repeatedly until SYS, ACT, SLAv, or S-1r shows on the display.  
Use <UP> or <DOWN> to select S-1r, Press <ENTER>, Begin using the IRC

### The functions of IRC:

#### Automatic Mode

Automatic Mode will enable you to run the automatic programs on the product.

Press AUTO on the IRC.

Press + or - to choose different auto programs.

To adjust the speed of the automatic program.

Press SPEED on the IRC

Press + or - to either increase or decrease the speed of the program.

#### Sound Active Mode

Sound Active Mode will enable the product to respond to music and follow below actions.

Press sound button.

Adjust the sound sensitivity.

Press sensitivity button.

Press + or - to either increase or decrease sound sensitivity.

#### Manual Color Control.

To choose a specific color with the IRC.

Press MANUAL on the IRC.

Press any number between 0-9 to choose your color.

To manually control the RGB percentage.

Press MANUAL on the IRC.

Press R, G, or B to choose your color.

Press the number (percentage) you desired

Press the button of %.

For example:

[MANUAL] -> [R] -> [5] -> [0] -> [%], red changes as 50%.

strobe control.

Follow below actions.

Press the strobe button on the IRC, Use + o - to adjust strobe speed.

Fade/snap.

Press the button of Fade/snap, Use + or - to adjust speed.

BLACK OUT.

Use the button of BLACK OUT to turn on or turn off.

Press the BLACK OUT to turn off.

Press Auto button to turn on and press BLACK OUT to turn on or turn off with power of the product.

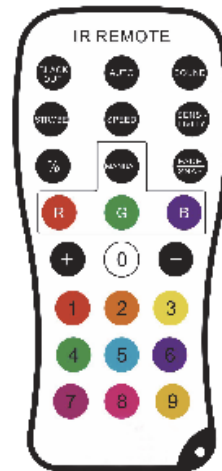

## **DMX Mode Auto Sync**

It offers wireless control of two or more products with a single DMX controller. To set syncing function for DMX functionality automatically, do the following:

### **For the transmitting product.**

Press <MODE> repeatedly until SYS, ACt, SLAv, or S-1r shows on the display.

Use <UP> or <DOWN> to select SYS.

Press <ENTER>.

Press <UP> or <DOWN> until S-tr appears on the display.

Press <ENTER>.

Press <UP> or <DOWN> until dtA.S appears on the display.

Press <ENTER>.

The display should show dt.AU.

### **For the receiving product(s).**

Press <MODE> repeatedly until SYS, ACt, SLAv or S-1r shows on the display.

Use <UP> or <DOWN> to select SYS.

Press <ENTER>.

Press <UP> or <DOWN> until S-tr appears on the display.

Press <ENTER>.

Press <UP> or <DOWN> until dRA.S appears on the display.

Press <ENTER>.

The display should show dR.AU.

Once the steps above are done, press and hold <AUTO> on the transmitter for about 20 seconds and the signal LED of receiver will flash to indicate sync is activated.

Cancel Auto Sync.

Press the Auto button of the receiving product until the signal stops flash, which means the between the receiver and transmitter is cancelled.

Auto Sync for receivers and transmitters:

Repeat operations, match the next group after finishing matching the first group. (Power off other fixtures when you follow the actions and multiple groups can not be matched at the same time)

One transmitter to multiple receivers.

Follow the instructions and set one as transmitter, the others as receivers, set the auto Sync between one receiver and one transmitter, and then power off the receiver, match another pair. Power on all the receivers after finishing, multiple receivers can be controlled by one transmitter.

## **DMX Mode Manual Sync:**

It can wireless control of two or more products with a single DMX controller. To manually set up the syncing function for DMX functionality, do the following.

### **For the transmitting product.**

Press <MODE> repeatedly until SYS,ACt,SLAv,or S-1r shows on the display.

Use <UP> or <DOWN> to select SYS.

Press <ENTER>.

Press <UP> or <DOWN> until S-tr appears on the display.

Press <ENTER>.

Press <UP> or <DOWN> until dt.CH appears on the display.

PRESS <ENTER>.

Use <UP> or <DOWN> to select the transmitting signal (dt.01-dt.16).

**For the receiving product(s).**

Press <MODE> repeatedly until SYS, ACt, SLAv, or S-1r shows on the display.

Use <UP> or <DOWN> to select SYS.

Press <ENTER>.

Press <UP> or <DOWN> until S-tr appears on the display.

Press <ENTER>.

Press <UP> or <DOWN> until dR.CH appears on the display.

Press <ENTER>.

Use <UP> or <DOWN> to select the receiving signal (dr.01 - dr.16). The channel. number should match the transmitting signal you chose in the prior steps.

Two products can be matched after finishing above steps.

Note: one transmitter can be used with multi receivers. Follow this actions and set one as transmitter, the others as receivers, one transmitter can be used with multi receiver products.

**IR/standalone mode auto Sync**

Two or more products can be controlled with no external controllers or with the IRC. To automatically set up syncing function for IR/standalone functionality, do the following.

**For the transmitting product:**

Press <MODE> repeatedly until SYS, ACt, SLAv, or S-1r shows on the display.

Use <UP> or <DOWN> to select SYS.

Press <ENTER>.

Press <UP> or <DOWN> until S-tr appears on the display.

Press <ENTER>.

Press <UP> or <DOWN> until tA.s appears on the display.

Press <ENTER>.

The display should show t-AU.

**For the receiving product(s).**

Press <MODE> repeatedly until SYS, ACt, SLAv, or S-1r shows on the display.

Use <UP> or <DOWN> to select SLAv.

Press <ENTER>.

Press <UP> or <DOWN> until rA.S appears on the display.

Press <ENTER>.

The display should show r-AU.

Once the steps above are done, press and hold <AUTO> on the transmitter for approximately 20 seconds. The signal LED of the receiver will flash to indicate sync is activated.

Note :

**cancel IR/standalone Auto Sync**

Press the Auto button of the receiver until the indicator stops flash, which means Sync data is cancelled.

**IR/standalone Auto Sync of multiple receivers and transmitters.**

Repeat operations, match the next group after finishing match the first group. (Power off other fixtures when you follow the actions and multiple groups can not be matched at the same time)

**One transmitter to multiple receivers:**

Follow the instructions and set one as transmitter, the others as receivers, set the auto Sync between one receiver and one transmitter, and then power off the receiver, match another pair. Power on all the receivers after finishing, multiple receivers can be controlled by one transmitter.

**Note:**

**The distance of receiver and transmitter should be between 0.6 meter and 10 meter.**

## Master/slave mode

### Standalone master/slave

The Master/Slave Runway Effect enables one product (the “master”) to control the actions of one or more other products (the “slaves”) in sequential order for a “runway” effect without the need of a DMX controller. The master product will be set to operate in specific automatic modes, while the slave products will be set to operate in slave mode. Once set and connected, the slave products will operate in unison with the master. Configure the products as indicated below.

- Connect the DMX input of the first slave product to the DMX link output of the master. The slave product will automatically switch to slave mode. The display will show SLA.
- Connect the DMX input of the subsequent slave products to the DMX link output of the previous slave.
- Set the Master as standalone mode after finishing all above actions.

Master/slave runway effect can be displayed in standalone mode, auto programs A014-A020 on the master product can achieve this function.

### Note:

Never connect a DMX controller to a DMX string configured for Master/Slave operation because the controller may interfere with the signals from the master product

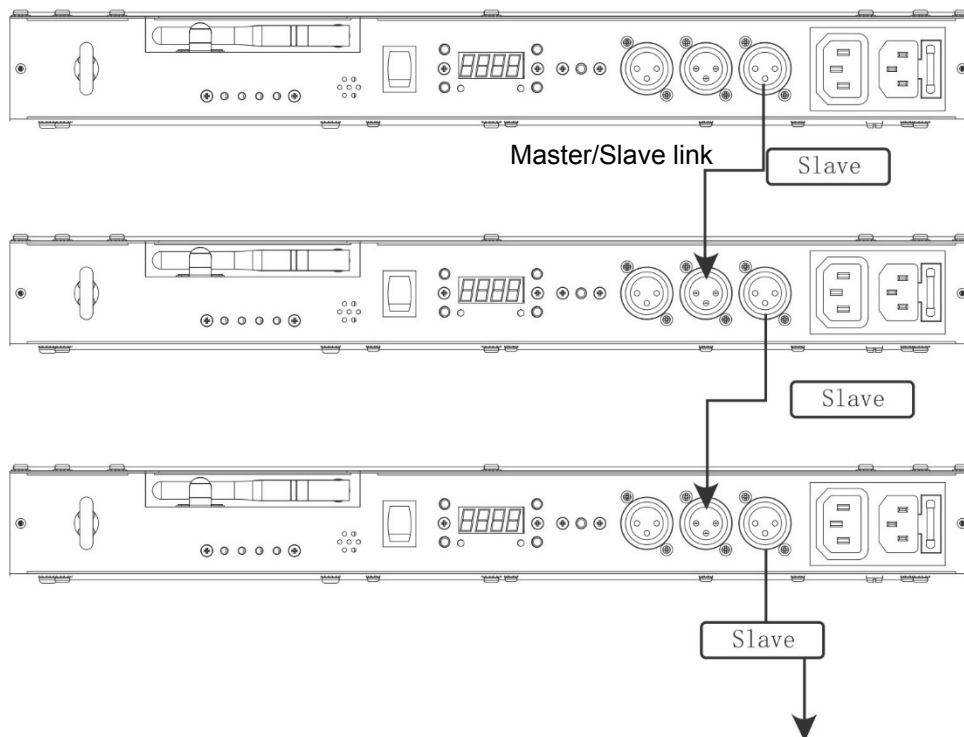

### Master/slave mode with DMX signal

The Master/Slave with DMX signal enables one product (the “master”) to control the actions of one or more other products (the “slaves”). Link the master and slave, once set and connected, the slave products will operate in unison with the master. Configure as indicated below.

- Connect the DMX controller to the DMX input of the master.
- Connect the DMX input of the first slave product to the DMX output of the master. The slave product will automatically switch to slave mode. The display will show SLA when this occur.
- Connect the DMX input of the subsequent slave products to the DMX link output of the previous slave.
- Once your setup is complete, SYS is shown on the master.

## Multi-groups connecting with DMX

Wonderful colors and beautiful lighting effect can be displayed by multi-groups of products controlled by DMX512, DMX512 signal is received and transmitted by the the first product for each groups.

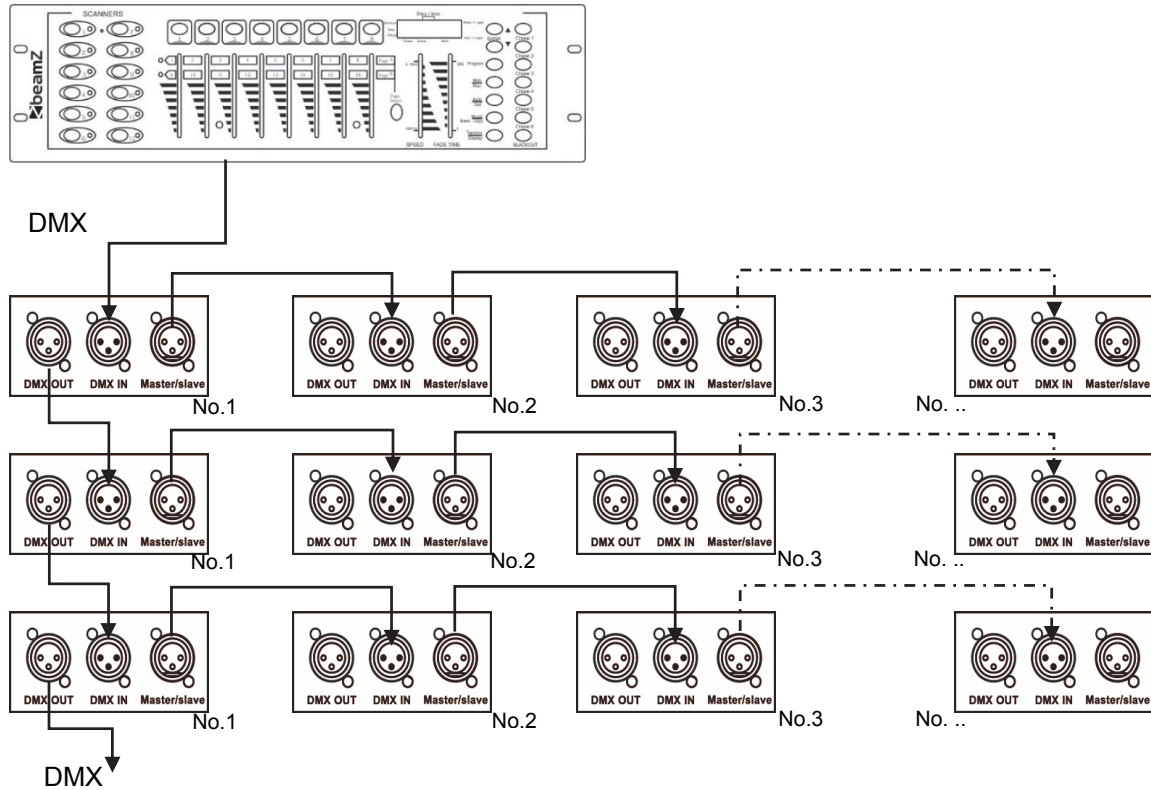

## Out-of-factory parameter setup

Press the mode button for about five seconds to recover the out-of-factory parameter.

## Charge the battery

Built-in 12V 8.8AH Lithium battery and can work 6 hours with full charge. When the battery life is less than 25%, the indicator will flash, please charge the battery about six hours. There is a relay between the lithium battery and electric supply and it makes sure that the product can be supplied power prior to the battery, the battery will supply power without electric supply.

Note:

With overcharge and discharge protections and it is no harm to the battery. It takes time to interchange between the battery and power supply, so in order to make the actions in unison, the software of the first product needs to be reset.

## Reset the software

Press <MODE> button repeatedly until SYS,ACT,SLAV or S-Ir is displayed.

Use <UP> or <DOWN> button until SYS is displayed.

Press <ENTER>.

Use <UP> or <DOWN> button until SAAd is displayed.

Press <ENTER>.

## MAINTENANCE

The unit should be cleaned periodically to ensure the optimum performance, the smudginess can decrease the life of light and the output of light is affected by the dust which can make the machine overheating. In general, make the maintenance at least two times a month. Be sure to power off the unit before cleaning .

Do not clean until the unit recovers normal temperature since high temperature for using, use the lens tissue or soft cotton cloth with alcohol to wipe gently.

Cleaning frequency depends on the environment in which the fixture operates, damp, smoky or dirty surrounding can cause greater accumulation of dirt on the optics. Never rub or press strongly on the panel.

## SPECIFICATION

Voltage.....	100-240V AC 50/60Hz
Input current .....	0.4A
Power.....	99W
Fuse.....	2A 250V
Light source .....	192 LEDs
.....	64x Red
.....	64x Green
.....	64x Blue
Built-in lithium battery .....	12V 8.8Ah
Wireless DMX frequency .....	2.433GHz – 2.481GHz
Distance:.....	R-T signal far from 250 meters
Weight.....	2.8kg
Size.....	L482 x W124 x H52mm



tronios  
Sound & Light

## CE & R&TTE DECLARATION OF CONFORMITY

Importer: TRONIOS BV  
Bedrijvenpark Twente 415  
7602 KM - ALMELO

Tel : 0031546589299  
Fax : 0031546589298  
The Netherlands

**Product number: 150.570**

Product Description: Beamz, Wi-Bar 192 LED RGB Battery 2.4GHz DMX

Regulatory Requirement: EN 60598-1/-2-17:2009  
EN 62031:2008  
EN 61347-2-13:2007  
EN 300440-1/-2:2010  
EN 62479:2010  
EN 55015:2006/A2:2009  
EN61547:2009  
EN 301489-1/-3:2011/2012  
EN 61000-3-2/-3-3

The product meets the requirements stated in the above mentioned Standards. This certificate does not cover the aspects that may be relevant such as performance and fitness for purpose.

Almelo,

10-03-2012

Signature:

Specifications and design are subject to change without prior notice..

**[www.tronios.com](http://www.tronios.com)**

Copyright © 2013 by TRONIOS the Netherlands